

Advanced Materials

**HUNTSMAN**

Enriching lives through innovation

# THE COMPLETE TECHNICAL GUIDE FOR ADHESIVES

Science and Best Practices



**MADE POSSIBLE**



# ACCESS THE INTERACTIVE TECHNICAL GUIDE

With the objective of creating ever more qualitative content, we have developed an enhanced and interactive version of this guide for you.

[Access the Interactive Guide](#)

SEARCH BY  
KEYWORDS

ACCESS VIDEO  
TUTORIALS

BOOKMARK  
FAVORITES

EASILY SHARE  
CONTENT

CONTACT  
OUR EXPERTS

# TABLE OF CONTENT

**1.0 ADHESION SCIENCE AND TECHNOLOGY**

**2.0 SIMULATION FOR ADHESIVES SELECTION**

**3.0 SURFACE PREPARATION AND PRETREATMENTS**

**4.0 APPLICATION AND BONDING METHODS**

**5.0 PRECAUTIONS FOR HANDLING AND STORAGE**

06

36

60

88

104

# 1.0

# ADHESION SCIENCE AND TECHNOLOGY

This guide is designed to help engineers overcome the reservations sometimes held about the use of adhesive bonding.

It includes an overview of bonding techniques and shows how joints may be designed and pre-treated to make the best use of adhesive bonds.

This guide has its roots in the first uses of synthetic structural adhesives: the ARALDITE® brand is known and recognized worldwide in both industry and the home environment.



## **1.1 INTRODUCTION**

A few words about adhesives  
Huntsman industrial adhesives  
Designing to bond

## **1.2 ASSESSMENT OF BONDING**

Advantages of adhesive bonding  
Limitations of adhesive bonding

## **1.3 DESIGNING A BONDED JOINT**

Loading conditions  
Basic bonded joints  
Basic peel joints  
Basic butt joints  
Basic cleavage joints  
Basic cylindrical butt joints  
Practical bonded joints  
Reinforced bonded joints  
Numerical simulation of joint design  
Durability of bonded joints



## 1.1 INTRODUCTION

# A FEW WORDS ABOUT ADHESIVES



**Almost all industrial items produced are made up of components which need to be fixed together in some way. Mechanical fasteners such as screws, rivets or spot welds are frequently used, but engineers are increasingly choosing to use adhesive bonding. This assembly technique is well proven and capable of replacing or supplementing mechanical fastenings. Advantages of adhesive bonding include:**

- **Outstanding lap shear and peel strength**
- **Reduced component and/or assembly costs**
- **Improved product performance and durability**
- **Greater design freedom**
- **Less finishing operations**

Adhesive bonding is not a new topic; mankind has used adhesives or glues since the dawn of history.

The ancient Egyptians attached veneers to furniture with glue and prehistoric man is even believed to have used basic glues for attaching arrow heads and digging tools. These early glues were all natural substances made from plants, tree resins or animal parts. Nowadays, synthetic resins and polymers are commonly used, enabling much higher performance levels to be reached.

When components are bonded together, the adhesive first thoroughly wets the bonding surfaces, filling the gap between them before hardening to form a bond. Once hardened, the bond can withstand the stresses imposed during use. High-performance adhesives often harden through a chemical reaction and have a strong affinity to joint surfaces. Adhesive bonding is sometimes called chemical joining to differentiate it from mechanical joining.



# HUNTSMAN INDUSTRIAL ADHESIVES

Our industrial adhesives form extremely strong and durable bonds with plastics, metals, glass, rubber and many other materials.

Adhesives have been successfully used for many years in very demanding industrial applications including aerospace, automotive, wind energy, sport and leisure, railways, construction and medical equipment.

Our industrial adhesives form extremely strong and durable bonds with plastics, metals, glass, rubber and many other materials. Designers in just about every industry have found that bonding with Huntsman adhesives can provide the solution to the design challenges created by new materials, new applications and new manufacturing methods.

Our industrial adhesives are easy to use, but to ensure high-performance bonding it is key to closely follow the instructions supplied with our products.

## Key instructions for a successful bond

- Resin and hardener components must be carefully measured in the correct ratio (found in our technical datasheets) and thoroughly mixed together.
- Joint surfaces must be degreased and, when necessary, pre-treated.
- Minimum curing temperature and curing time must be observed (data given in the technical datasheets).
- Jigs or other fixtures must be used to prevent the bond surfaces from moving relative to one another during the curing process.
- Though only light pressure is needed, it should be applied as evenly as possible over the whole bond area. Excessive pressure may leave the joint with insufficient adhesive.



**At Huntsman we develop adhesives that meet the needs of many industries and we focus on one goal: making our customers' ideas possible.**

[▶ Watch the video](#)

## DESIGNING TO BOND

In order to get the best performance from an adhesive bond it is important to design the component for a bonded joint, rather than simply trying to bond parts designed for mechanical fastening.

Methods of application of the adhesive and the assembly of the components must always be considered at the design stage. Together, with the curing conditions, these determine the choice of adhesive to be used.

Computer simulation is a technique which is increasingly used for the design of adhesively-bonded structural joints. Simulation offers engineers a reliable evaluation of joint deformation and strength. Comprehensive Material Models are available for the ARALDITE® adhesive range. Based on laboratory material characterization, the Material Models provide a wealth of information on the physical, mechanical and thermal behavior of our products. Material Models include detailed experimental data of adhesive mechanical properties (tensile and fracture properties), adhesion properties (lap shear, peel) and curing phenomenon (glass transition temperature, shrinkage, density, hardness).

Use of ARALDITE® Material Models allows engineers to achieve robust adhesive joint simulation, assisting adhesive selection and joint design, as well as greatly reducing the physical part testing required for the design process.

# ADVANTAGES OF ADHESIVE BONDING

Adhesive bonding can offer reduced stress, greater stiffness, improved aesthetic appearance and lower complexity for parts.

All of these advantages can ultimately translate into economic benefits: simplified design, easier assembly, lighter weight (reduced energy consumption) and extended service life.

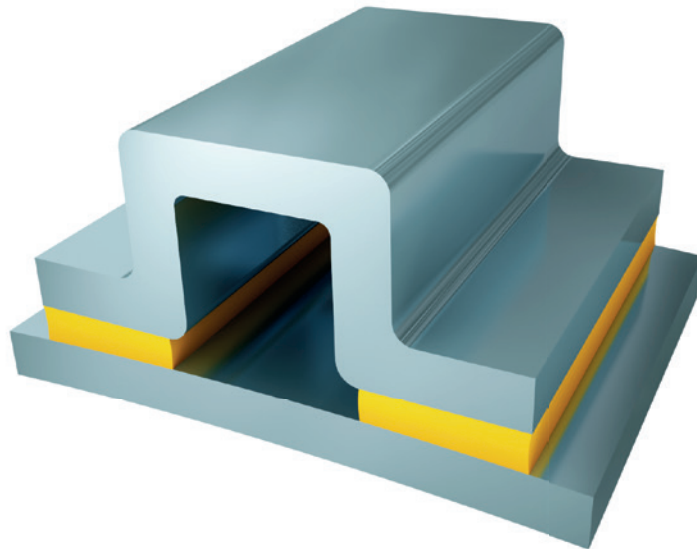

**FIG.1A STIFFENING EFFECT WITH BONDING**

The diagram shows how a joint may be designed to take advantage of the stiffening effect of bonding. Adhesive forms a continuous bond between the joint surfaces.

### CONTINUOUS BOND

The stress is uniformly distributed over the entire bond area when a load is applied whereas stress is highly concentrated in a few areas when spot welding or mechanical fasteners are used. Bonded assemblies will therefore typically provide a longer service life under load.

### IMPROVED APPEARANCE

Adhesive bonding gives a smooth appearance to parts. There are no protruding fasteners such as screws or rivets, and no spot welds marks.

### STIFFER STRUCTURES

The continuity of a bonded assembly will produce stiffer structures. Alternatively, if increased stiffness is not needed, the weight of the structure can be decreased while maintaining the required stiffness. (Figure 1A and 1B)

### COMPLEX ASSEMBLIES

Complex assemblies can often not be joined together by any other fastening technique. Composite sandwich structures are a typical example.

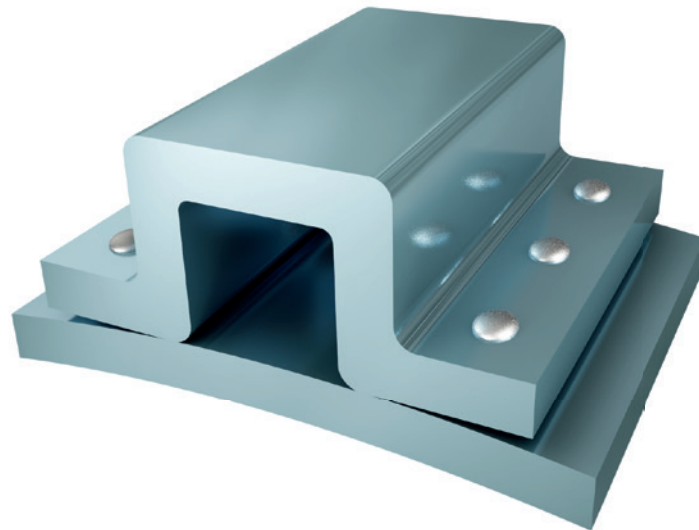

**FIG.1B STIFFENING EFFECT WITH RIVETING**

Rivets and spot welds pin the surfaces together only at specific points. Bonded structures are consequently much stiffer and loading may be increased (by up to 30 - 100%) before buckling occurs.

# ADVANTAGES OF ADHESIVE BONDING

## DISSIMILAR MATERIALS

Adhesives can join different materials together – materials that may differ in composition, stiffness, coefficients of thermal expansion, or thickness.

## HEAT SENSITIVE MATERIALS

Adhesive bonding does not require high temperatures, making it highly suitable for joining heat-sensitive materials prone to distortion or to a change in properties (e.g. from the heat of brazing or welding processes).

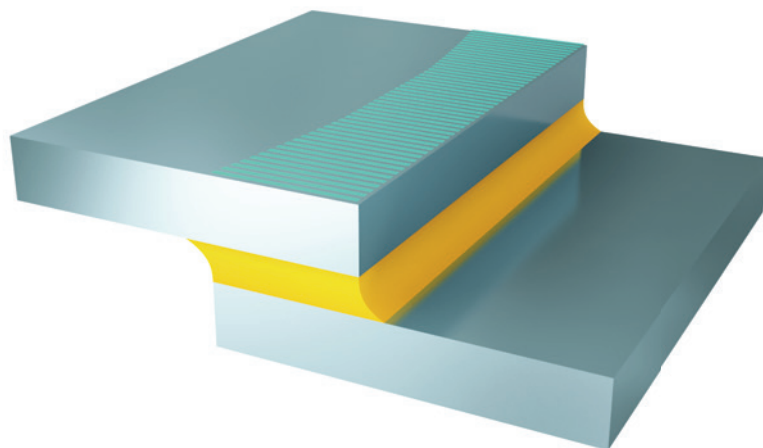

**FIG.2A STRESS DISTRIBUTION IN LOADED JOINTS WITH BONDING**

The bonded joint shown here is uniformly stressed. A welded joint would also show good stress distribution, but the heat of welding may reduce the metal's properties in the vicinity of the weld, reducing overall strength.

### REDUCED CORROSION

The continuous adhesive bond forms a seal. The joint is consequently leak proof and less prone to corrosion.

### ELECTRICAL CONDUCTION

Some adhesives are specifically formulated to offer high electrical conductivity. This is particularly useful for electronic applications.

### ELECTRICAL INSULATION

The adhesive bond can provide an electrically insulating barrier between components.

### VIBRATION DAMPENING

Adhesive bonds have good dampening properties which may be useful for reducing sound transmission or vibration.

### REDUCED STRESS CONCENTRATION

A bonded joint may lead to an inherently safer structure, since reduced stress concentration means that fatigue cracking is less likely to be induced. Fatigue cracks will often propagate more slowly in a bonded structure than in a riveted structure – or even in a solid machined part, because the bond lines will typically stop crack formation. (Figure 2A and 2B)

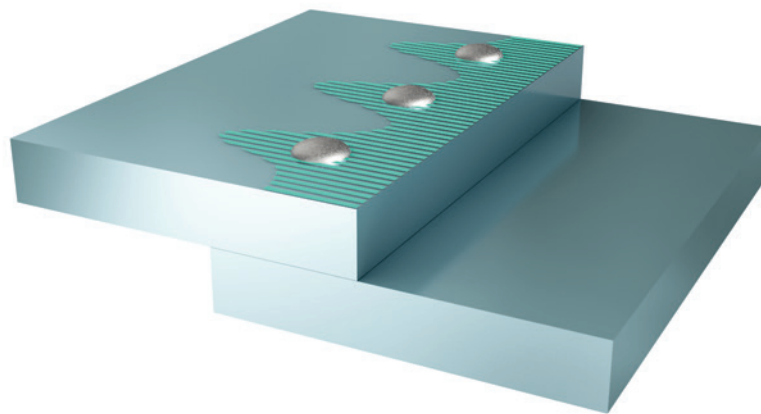

**FIG.2B STRESS DISTRIBUTION IN LOADED JOINTS WITH RIVETING**

The riveted joint is highly stressed in the vicinity of the rivets. Failure tends to initiate in these areas of peak stress. A similar distribution of stress occurs with spot welds and bolts.

# LIMITATIONS OF ADHESIVE BONDING

As with most techniques, adhesive bonding has some limitations which must be considered when designing bonded parts and planning for their production. With sufficient foresight, many of the limitations can be mitigated during the design and planning stage.

## TEMPERATURE RESISTANCE

Adhesives are produced from a class of materials known as polymers, plastics or synthetic resins and have some inherent limitations. They are not as strong as metals, but the difference is offset by the increased surface contact area provided by the bonded joints. Bond strength decreases with increasing temperature and the strain properties of the adhesive move from elastic to plastic. This transition is usually in the temperature range of 20 – 220°C (68 - 428°F); the transition temperature depends on the type of adhesive used.

## CHEMICAL RESISTANCE

The resistance of bonded joints to the in-service environment is dependent on the properties of the polymer from which the adhesive is made. Possible exposure of the bonded structure to oxidizing agents, solvents, etc., must be kept in mind when selecting the adhesive type to be used.





### **CURING TIME**

With most adhesives, maximum bond strength is not achieved immediately as it is with mechanical fastening or welding. The bonded assembly must be supported while the bond strength is developing. Hybrid joining, whereby mechanical fasteners (e.g. screws or rivets) are used in addition to the adhesive, can overcome the requirement for support during bonding.

### **SURFACE PREPARATION**

The quality of the bond may be adversely affected if the surfaces are not readily wetted by the adhesive during the bonding process (see "Surface preparation and pretreatments" section).

### **PROCESS CONTROLS**

Ensuring consistently good results may necessitate the setting up of unfamiliar process controls. A poorly executed bonding is often impossible to correct.

### **IN SERVICE REPAIR**

Bonded assemblies are usually not easily dismantled for repair.

### **HEALTH AND SAFETY**

High-performance structural adhesives are typically based on chemical products which present some environmental and health risks until they are fully cured. Suitable precautions must therefore be respected during mixing, application and bonding. Information is available for each product on the safety datasheet (SDS).

### **QUALITY MANAGEMENT**

Within the ISO 9000 quality standard, adhesive bonding is required to be treated as a "special process", since bond strength and durability cannot be fully verified by non-destructive testing (NDT).

This means that additional quality standards, such as DIN 2304-1 and DIN 6701 may have to be applied to meet quality management requirements.



# LOADING CONDITIONS

It is critical that an assembly which will ultimately be bonded is designed with bonding in mind, rather than simply bonding a design intended for welding or mechanical fastening.

When designing bonded joints the following aspects must be considered:

- Joint geometry
- Adhesive selection
- Adhesive performance properties
- Service conditions
- Stress in the joint
- Manufacturing process

Bonded assemblies may be subjected to tensile, compressive, shear or peel stresses, or a combination thereof (Figure 3). Adhesives are more resilient under shear, compression and tension stresses. They perform less effectively under peel and cleavage loading. A bonded joint needs to be designed so that the loading stresses will be directed along the lines of the adhesive's greatest strengths.

To indicate the typical adhesive performance properties, the Huntsman Advanced Materials technical datasheet will usually report shear strength and peel strength obtained on a range of standard substrates.



For example, the standard test method for shear (ISO 4587) uses a simple lap joint made from metal sheet, usually an aluminum alloy 25 mm wide with 12.5 mm bonded overlap. The mean breaking stress at room temperature will be in the range 5 to 45 N/mm<sup>2</sup> depending on the adhesive.

At the top end of this breaking stress range, bonded assemblies made from aluminum alloy up to 1.5 mm thickness will often cause the substrate to yield or break (the lap joint is only one of several different types of bonded assemblies). The breaking load of a lap joint is proportional to its width, but not to its overlap length.

Although the breaking load will increase as overlap length is increased, the mean breaking stress will be reduced. The strength of a joint is a complex function of the stress concentrations set up by the load. In a simple lap joint made from thin metal sheet there are two sorts of stress: shear and peel.

Both the shear and peel stresses vary along the length of the joint, with concentrations at the ends. Alternative joint designs are shown hereafter where these stresses are more evenly distributed. The efficiency gained results in joints of greater strength.

# LOADING CONDITIONS

**FIG.3 LOADING CONDITIONS**

A bonded joint can be loaded in five basic ways (as shown in the adjoining diagrams). Cleavage and peel loading are the most severe as they concentrate the applied force into a single line of high stress. In practice, a bonded structure has to sustain a combination of forces. For optimum strength, the bonded assembly should be designed in such a way as to avoid cleavage and peel stresses.

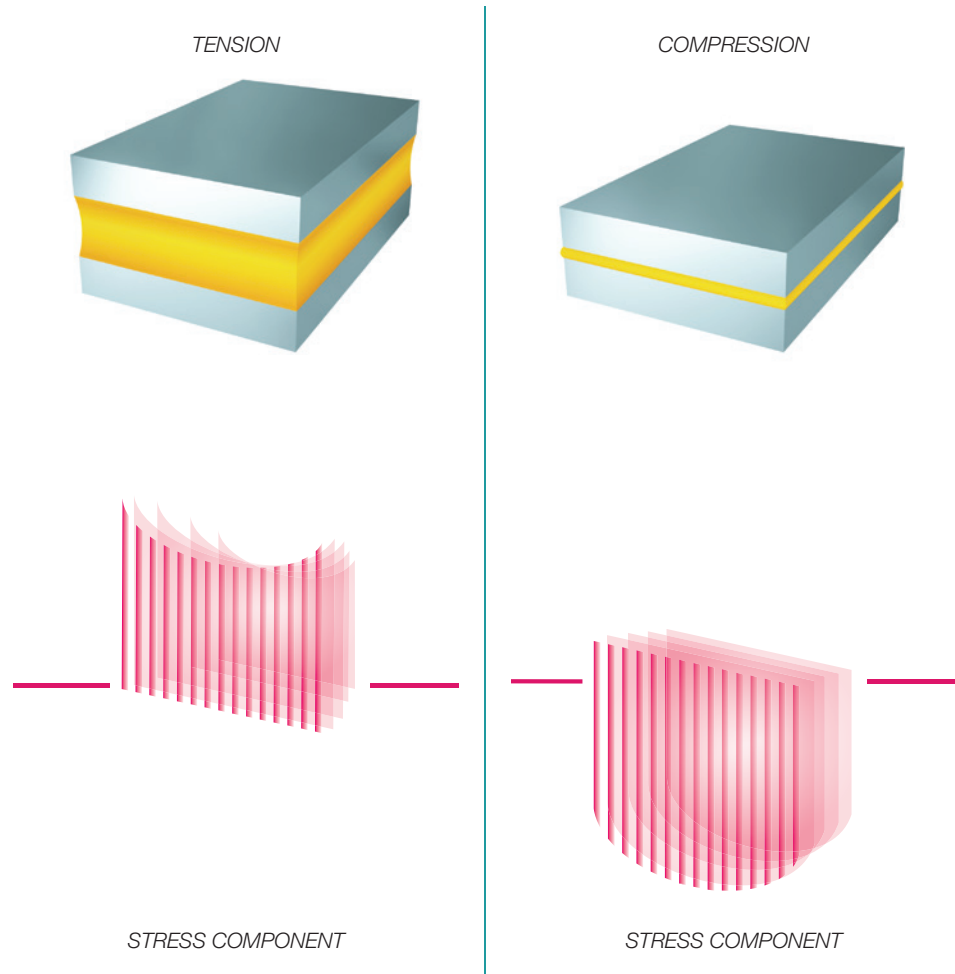

*SHEAR*

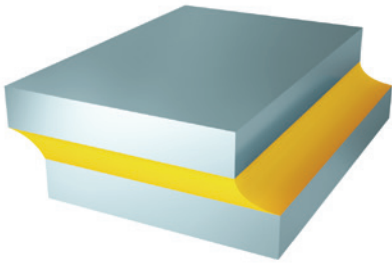

*CLEAVAGE*

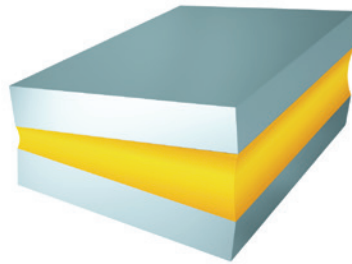

*PEEL STRESS*

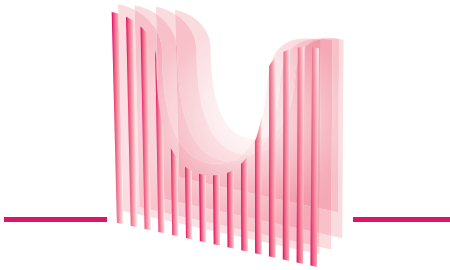
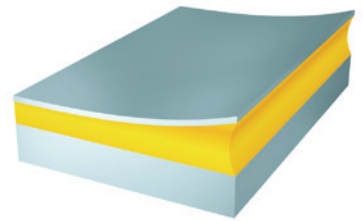

*STRESS COMPONENT*

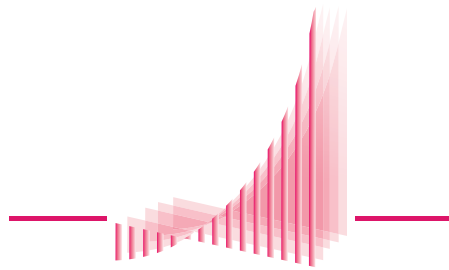

*STRESS COMPONENT*

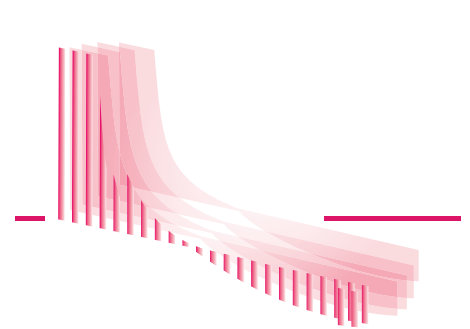

*STRESS COMPONENT*



### 1.3 DESIGNING A BONDED JOINT

# BASIC BONDED JOINTS

The basic types of bonded joints are shown in the following diagrams. In practice, a combination of two or more basic types may be used – and the relative dimensions (and areas of bonded surface) of the joints may vary from those shown in the adjoining diagrams.

Tapering of the ends of lap joints or scarf joints serve to distribute the stress more uniformly and reduce stress concentration.

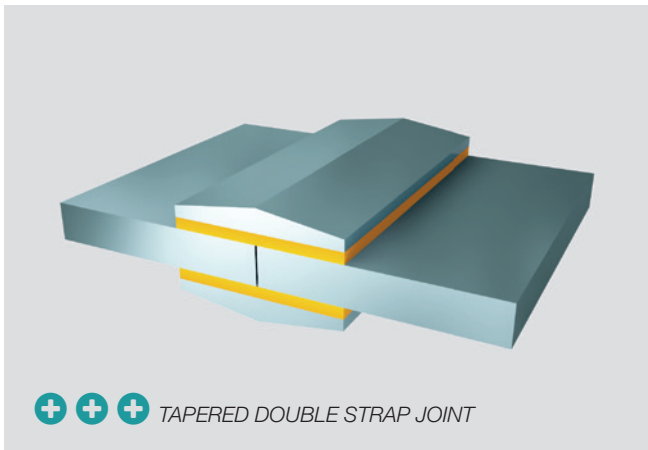
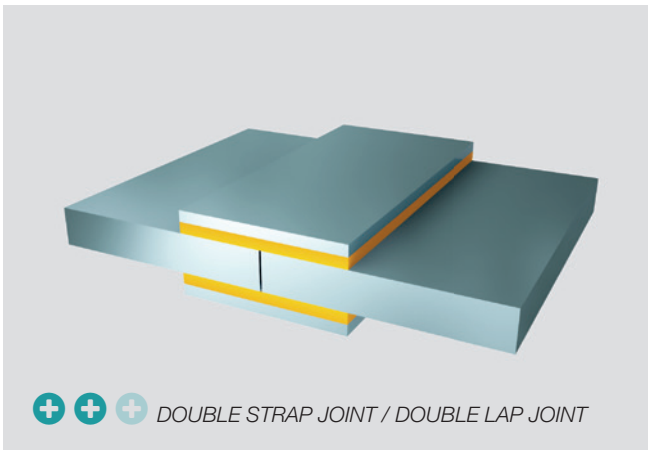
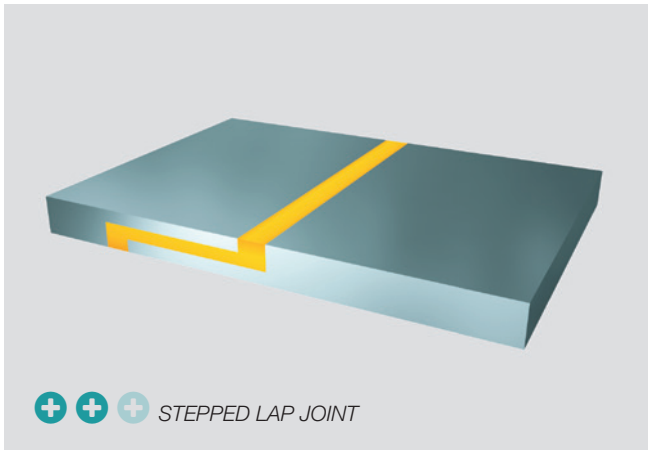
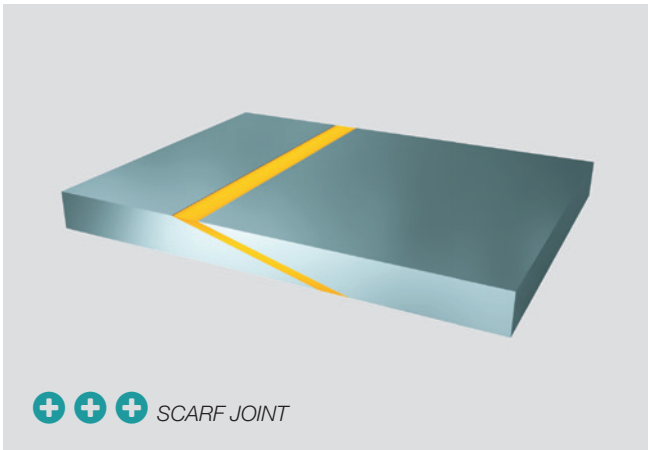
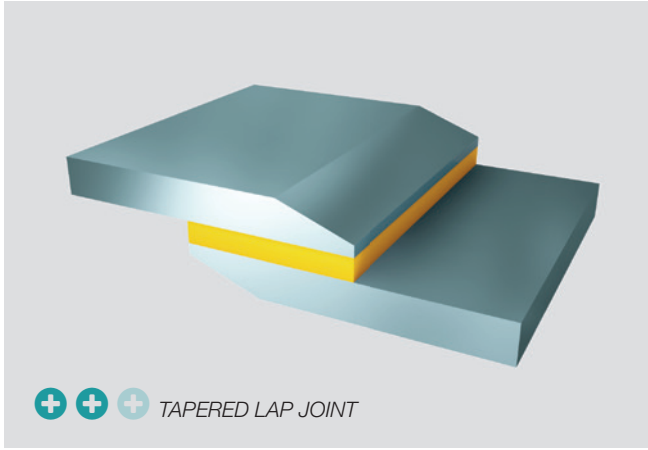
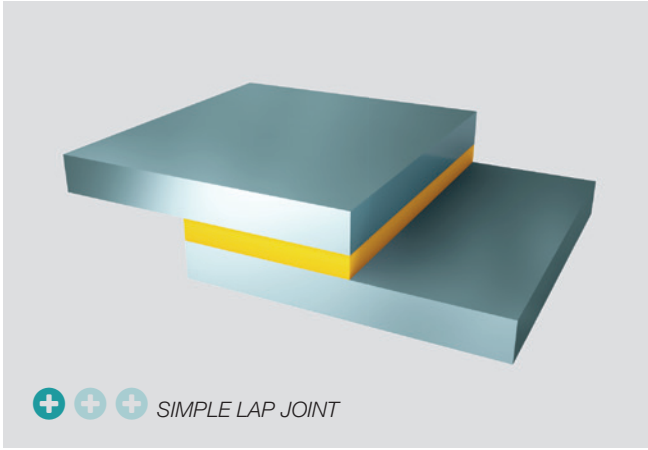

# BASIC PEEL JOINTS

A peel joint can be designed such that the forces acting on it become compression forces, making a much stronger joint.

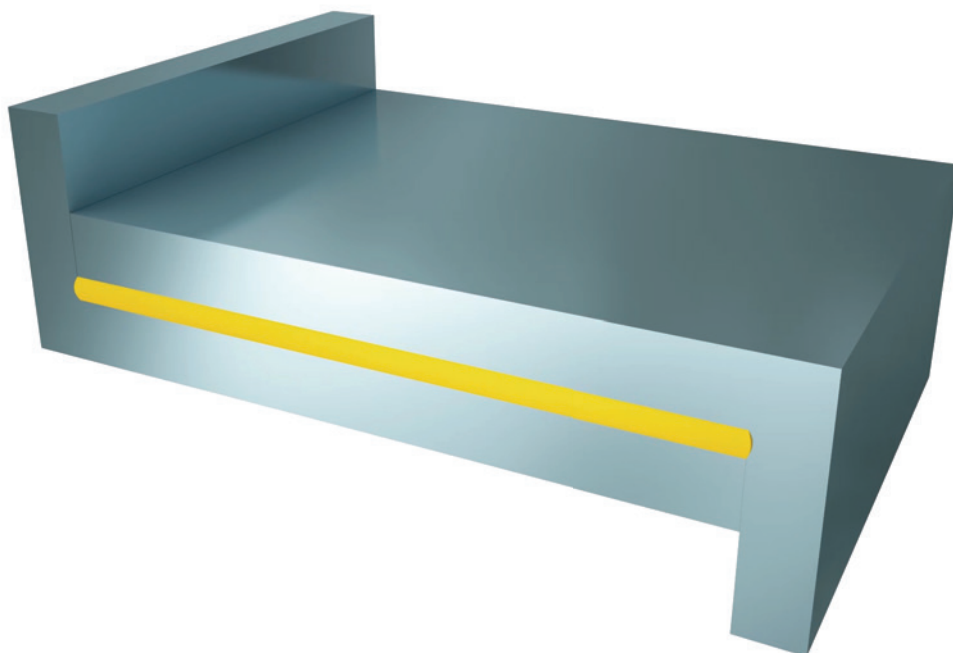
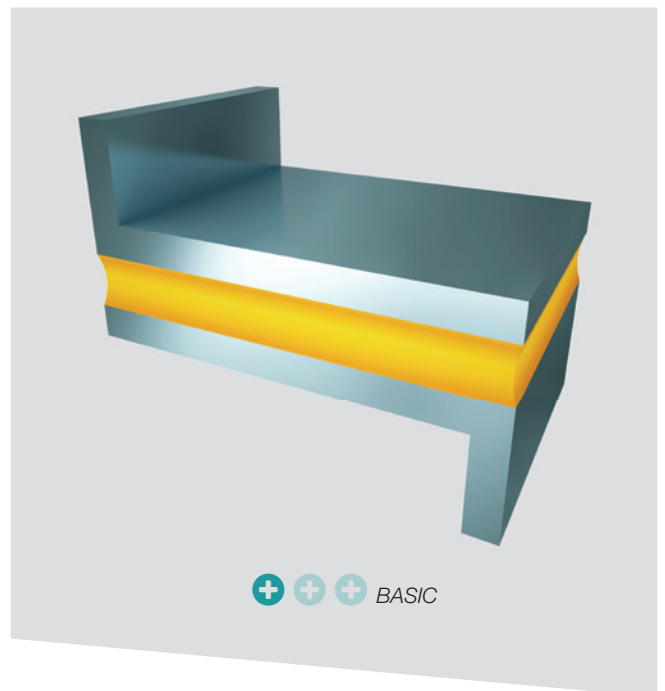

+++ STRENGTHENED



# BASIC BUTT JOINTS

By adding a reinforcing plate to this butt joint, the forces run along a much stronger shear joint.

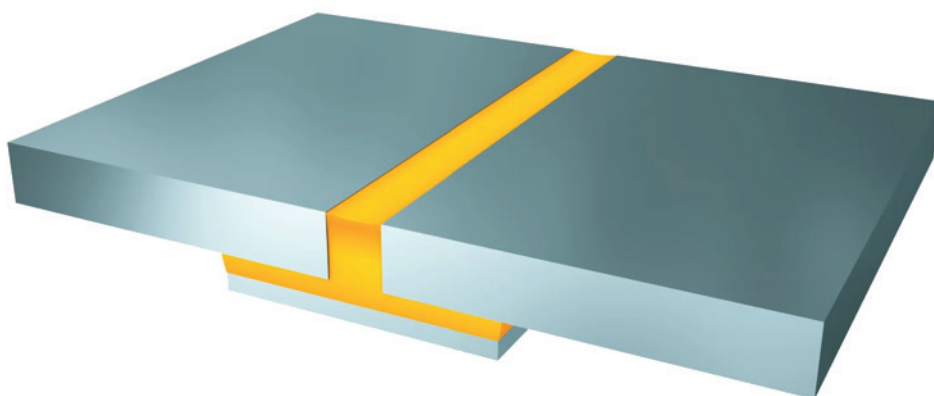
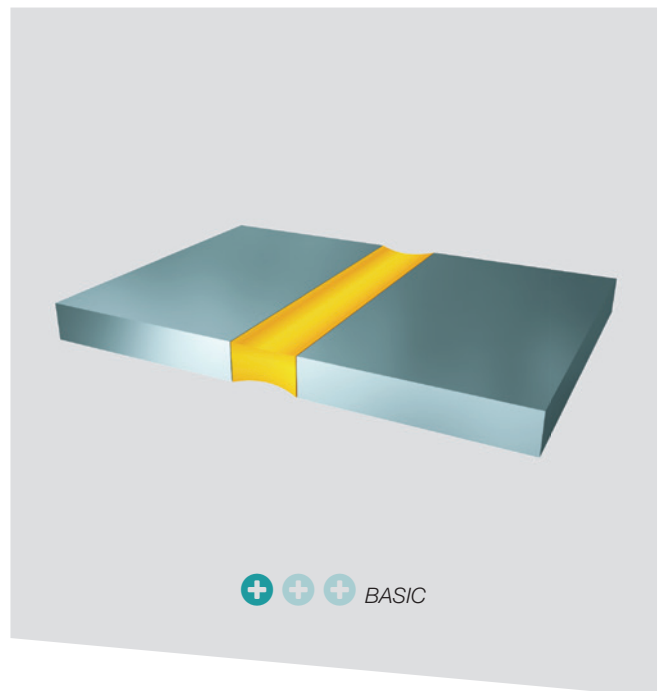

+++ STRENGTHENED

# BASIC CLEAVAGE JOINTS

Weak cleavage joints can be strengthened through design, in this instance by adding a U-section to the previously bent sheet.

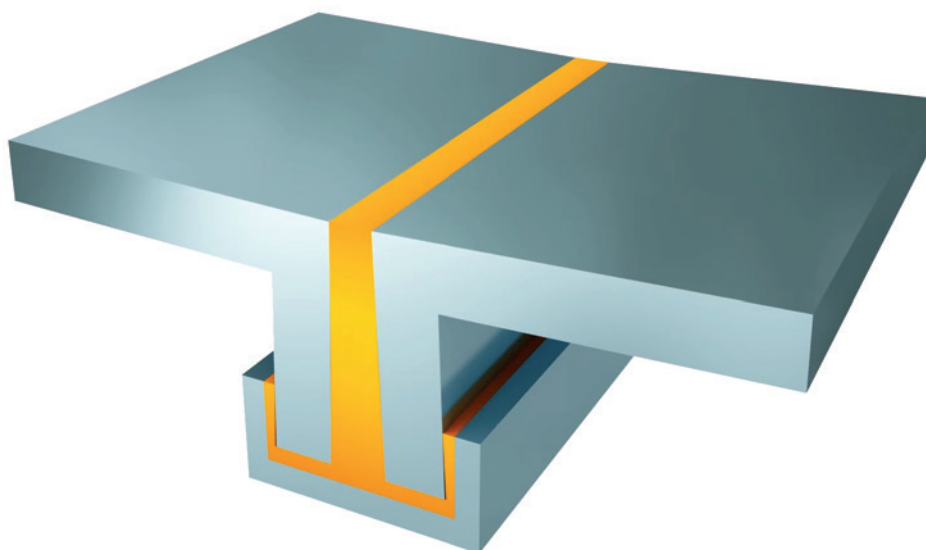
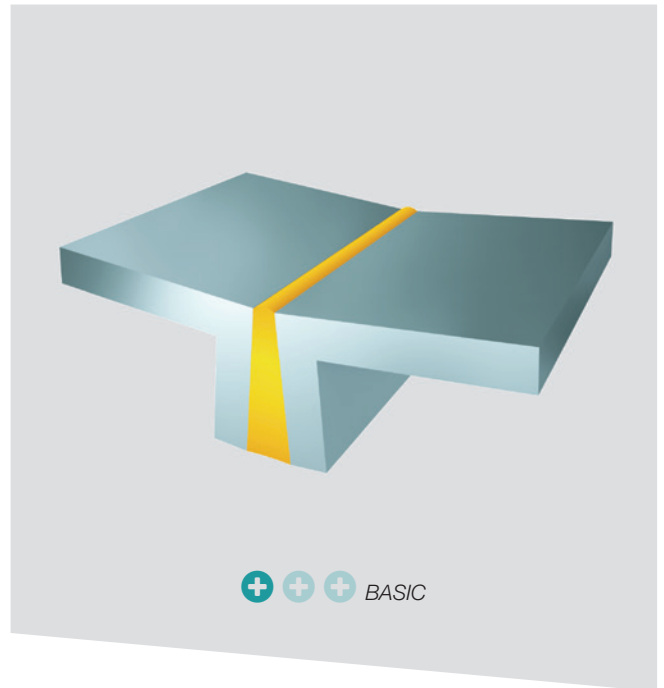

+ + + STRENGTHENED

# BASIC CYLINDRICAL BUTT JOINTS

By sleeving cylindrical butt joints, the forces run along a much stronger shear joint.

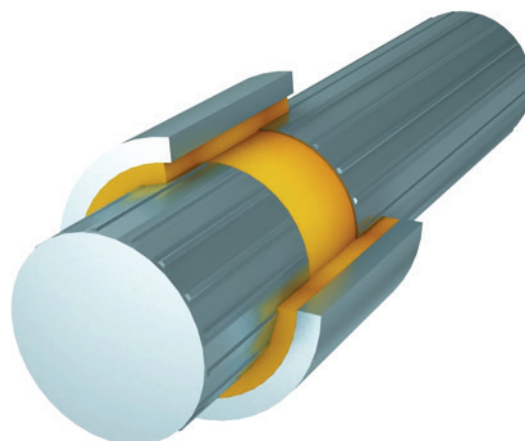
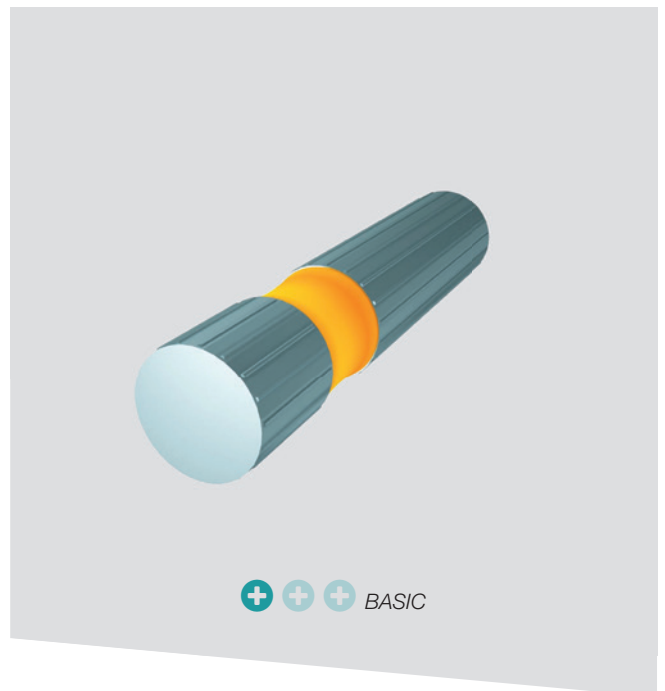

+++ STRENGTHENED

### 1.3 DESIGNING A BONDED JOINT

# PRACTICAL BONDED JOINTS

Certain metals, especially mild steel, are easily bent or folded to form advantageous joints.

- (A) shows a development from the simple lap joint, (B) a toggled joint.
- (C) shows further developments.
- Closed box structures (D) from formed sheet metal are easily produced using a folding and bonding technique.

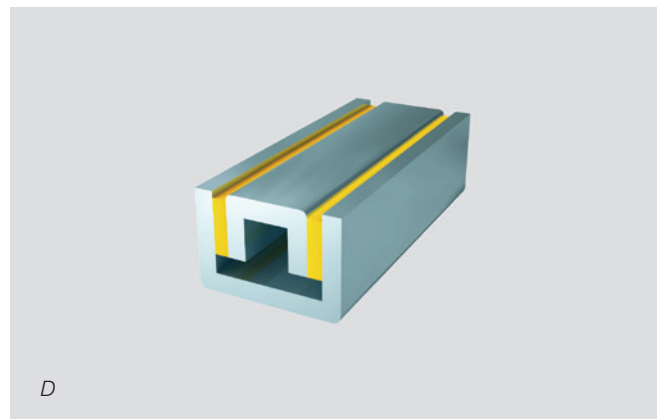
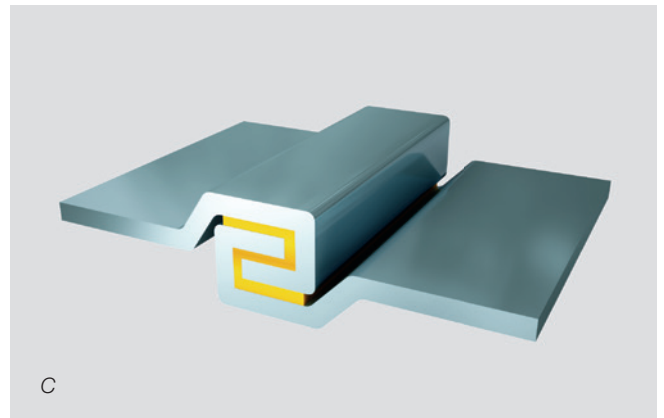
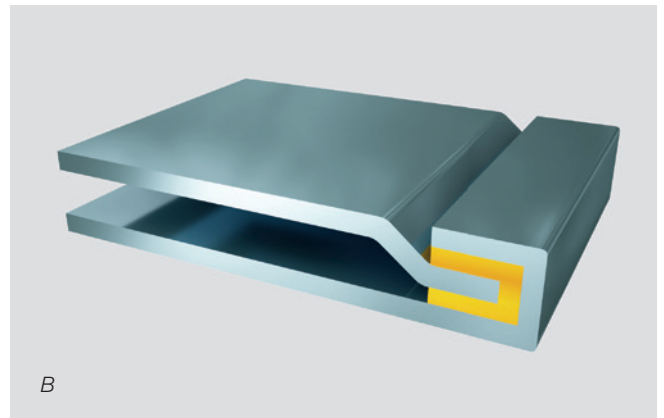
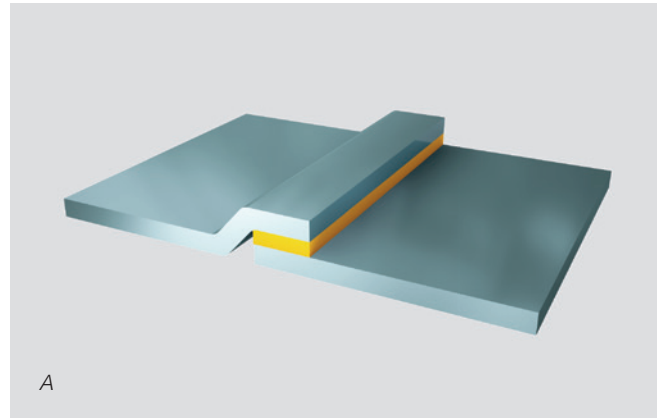



Multi-layer structures may be built up by adhesive bonding and may also be bonded to other parts.

In the adjoining diagram, an edge member is bonded into a sandwich panel. On loading, the stresses will be transferred into the panel. The honeycomb core is itself assembled and bonded to the facing sheets with adhesives.

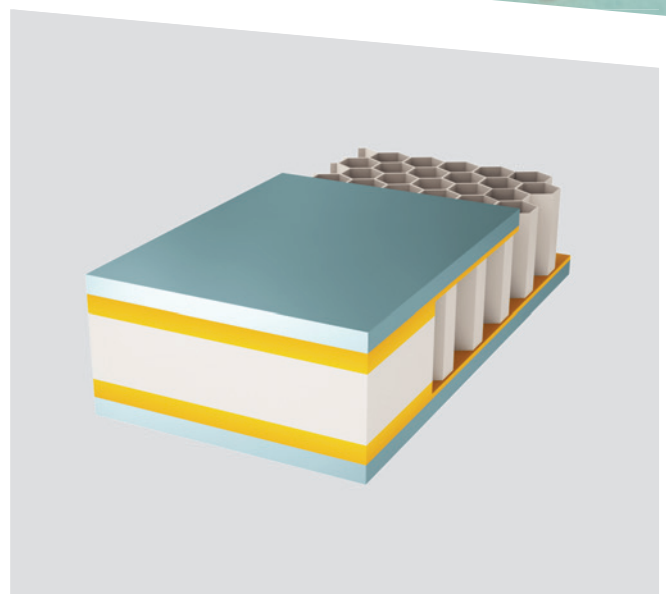

# REINFORCED BONDED JOINTS

## Joints using profiles

Sheets or plates that cannot be bent and folded may be bonded together by means of purpose made profiles. Tapering removes the high stress concentrations caused by abrupt change in section.

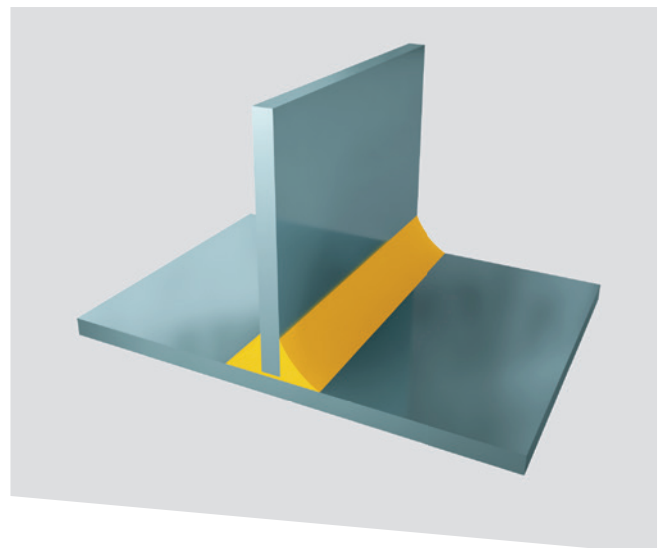
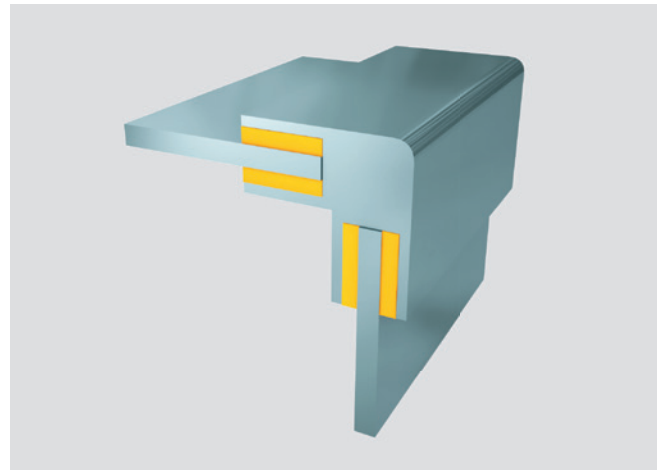

## Bonded frameworks

Framework structures of square or round tubes, or simple profiles, may utilize plugs or bosses at the joints. Use of these additional pieces greatly increases the area of bonded surface at the joint.

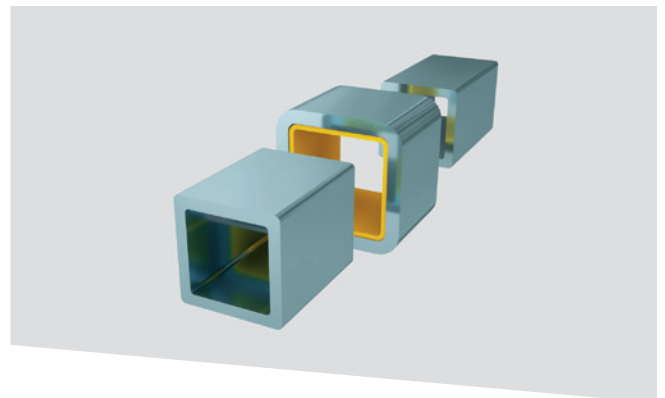
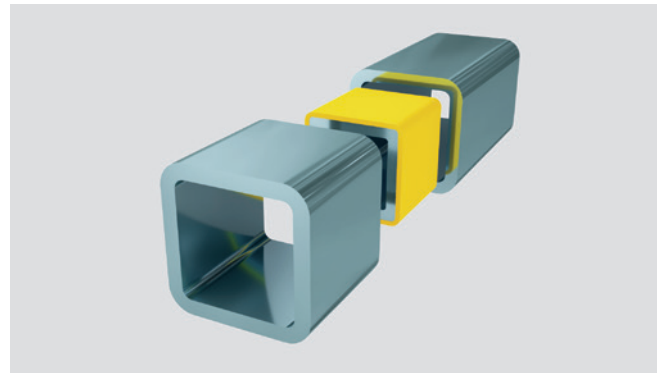

## Stiffening of large thin sheets

Large sheets of thin-gauge material may be stabilized by bonding stiffeners made of the same material. The diagram shows a 'top hat' stiffener which was cut away towards the edge of the sheet in order to reduce stress concentrations. The effect is similar to that of the scarf joint.

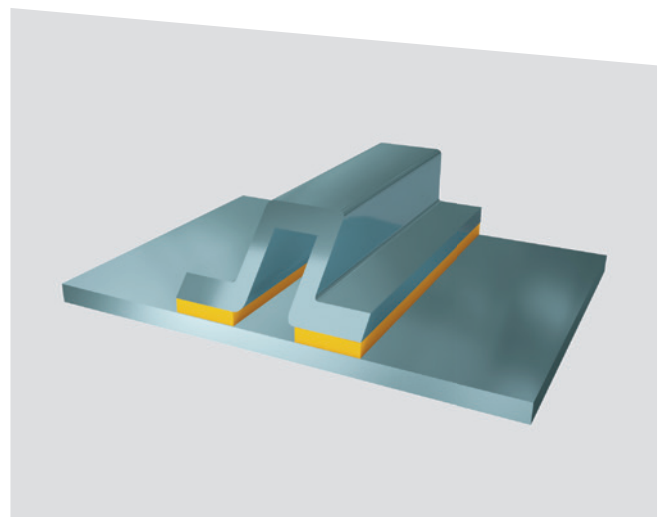

# NUMERICAL SIMULATION OF JOINT DESIGN

Simulation of adhesively-bonded joints is now a common design tool for engineers.

Robust numerical simulation of adhesively-bonded structures relies on detailed Material Models which are based on solid experimental measures. These models should reflect the temperature dependence of the adhesive material.

Material Models are available from Huntsman which provide key experimental data for the range of ARALDITE® adhesives. This aims to help engineers achieve a robust simulation of adhesive joints.

Reliable evaluation of the joint deformation and strength under thermo-mechanical loading is a major challenge in the design of adhesively-bonded structures.

Evaluations must consider the combined effect of design parameters, such as joint configuration and bond line thickness, together with the varying properties of the adhesive material over the process and operating conditions.

Reliability analysis of adhesively-bonded assemblies therefore often necessitates use of complex numerical computation techniques such as finite element analysis (FEA).



## TENSILE PROPERTIES

Tensile tests measure the force required to break an adhesive specimen and the extent to which the specimen stretches or elongates up to breaking point. Tensile testing provides the strength, modulus and elongation of the material over a range of temperatures.

## POISSON'S RATIO

Poisson's ratio is a measurement of the relationship between how far a material is stretched and how thin it becomes during the stretching process. Poisson's ratio is commonly used in the design of structures to allow engineers to predict dimensional changes of a given material when under load.

## FRACTURE TOUGHNESS

A major consideration in the design of adhesively-bonded structures is the possibility of crack growth leading to joint failure, either within the adhesive or at the adhesive-adherend interface. Fracture toughness testing simulates a small flaw in a standardized material specimen (using a pre-crack) and measures the load required to propagate the crack.

## LAP SHEAR STRENGTH

Lap shear strength is a measure of how much shear force can be exerted on a lap joint before failure occurs. It is a critical characteristic of any adhesive, as it serves as one of the indicators of bond strength and durability in use.

Key properties that help engineers achieve a robust simulation of adhesive joint can be found in the ARALDITE® Material Models.

---

## PEEL STRENGTH

Peel strength measures how much force is needed when two flexible adherends are bonded and then pulled apart. A T-peel test determines the peel strength of an adhesive by measuring the peeling force of a T-shaped bonded assembly of two flexible adherends.

## THERMAL EXPANSION

Linear Thermal Expansion is used to determine the rate at which a material expands as a function of temperature. This test can be used for design purposes and to determine if failure by thermal stress may occur.

## GLASS TRANSITION TEMPERATURE

Glass transition temperature is the temperature at which a reversible change in the adhesive occurs as it is heated, characterised by a transition from a rigid glassy state to a flexible elastomeric state. The glass transition temperature (T<sub>g</sub>) indicates the temperature range over which an adhesive may be used.

## VOLUMETRIC SHRINKAGE

The volumetric shrinkage signifies the contraction of polymeric adhesives which takes place during the hardening step, generally expressed as a percentage. The amount of shrinkage often depends on the temperature attained during the adhesive curing process.

## SHORE HARDNESS

Shore hardness is used to determine the relative hardness of softer materials such as adhesives. A durometer measures the penetration of a hardened indenter into the adhesive under a specified force.

## CURED DENSITY

Density represents the degree of compactness of an adhesive measured in mass per unit of volume. It is frequently used to follow variations in physical structure or composition of adhesives.

# DURABILITY OF BONDED JOINTS

The long-term performance of a bonded joint depends on the properties both of the adhesive and of the materials being joined.

The adhesive may be affected by high temperatures, or by exposure to water or chemicals. The durability of the joint will also depend on the effects of these agents on the materials being joined.

Above all, it will depend on the conditions of the joint surfaces when the bond was made. The best joints are made when the surfaces are absolutely clean and are completely wetted by the adhesive.

Durability of bonded joints necessitates control of pre-treatment of the surfaces. A poor surface condition usually results in a relatively low initial strength and reduced durability. A thick bond line gives lower initial strength (Figure 4). With most types of reactive adhesives, the application of heat to complete the curing process improves both initial strength and durability.

The user will need to assess the level of control required for these factors in order to produce a bonded joint suitable for the expected service conditions. For many applications, sufficient durability is obtained with easily achievable levels of surface pre-treatment, bond-line thickness control and cure-schedule monitoring.

Shear strength decreases if the bond line is too thick. The effect of increasing bond line thickness in simple lap joints made with cured epoxy adhesives is shown in the diagram (Figure 4). The optimum bond line thickness is in the range 0.1 to 0.5 mm. In very thin bond lines there is risk of incomplete filling of the joint due to contact between high points on the joint surfaces.

The bonded joints may need to resist sustained loads, which are either static or cyclical. Joint designs in which peel stresses are kept to a minimum offer the best durability. Cyclical fatigue testing of simple lap shear joints made with epoxy adhesives will often give failure values of ca 30% of the static breaking load (Figure 5).

**FIG.4 BOND LINE THICKNESS VS. SHEAR STRENGTH**

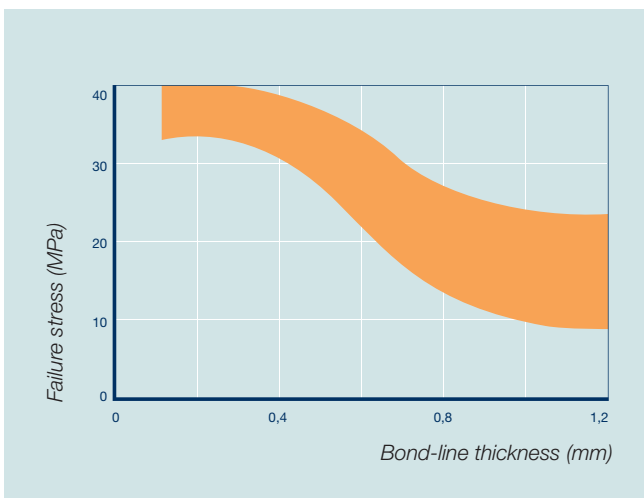

Adhesive strength at the interface is by its nature greater than the cohesive strength within the adhesive. The diagram shows that in this adhesive, the drop in strength occurs in the range 0.4 to 1.0 mm. In thicknesses greater than 1.0 mm, shear strength is approximately constant.

The exact shape of the curve depends on the characteristics of the adhesive. Toughened adhesives will maintain higher values in thicker bond lines, while more rigid adhesives will decline more quickly.

**FIG.5 FATIGUE STRENGTH (TENSILE) OF LAP JOINTS**

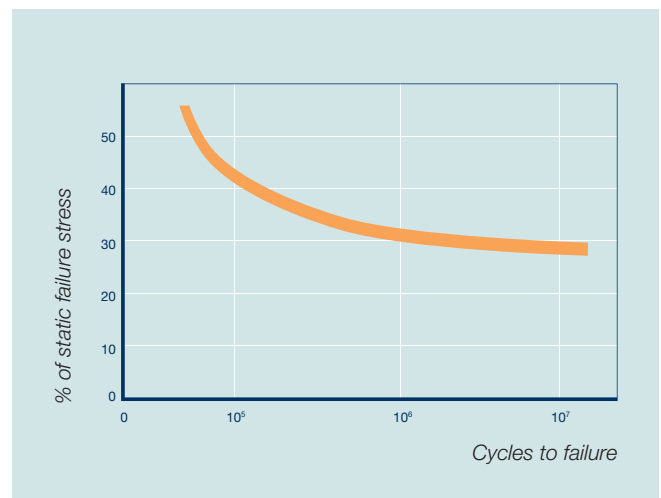

Adhesives are often used in applications where they are subjected to dynamic as well as static stresses. Small, repeated loads can lead to fatigue cracking. Over many load cycles, these cracks may propagate and ultimately lead to joint failure.

Cyclical lap shear testing may be used to determine fatigue resistance of an adhesive joint. A load is applied repeatedly and the number of cycles to failure is recorded. The load can be varied to build a full picture of fatigue performance.

# 2.0

# SIMULATION FOR ADHESIVES SELECTION

At Huntsman, all of our adhesives are tested in our ISO-accredited labs to ensure they deliver the desired properties and answer the specific needs of our customers.

By carrying out a wide range of thermo-mechanical characterization, we are also able to provide engineers with the required data for accurate numerical simulation of adhesive bonding.



- 2.1 INTRODUCTION**
- 2.2 TENSILE PROPERTIES**
- 2.3 POISSON'S RATIO**
- 2.4 FRACTURE TOUGHNESS**
- 2.5 COEFFICIENT OF THERMAL EXPANSION**
- 2.6 GLASS TRANSITION TEMPERATURE**
- 2.7 LAP SHEAR STRENGTH**
- 2.8 T-PEEL STRENGTH**
- 2.9 CURED DENSITY**
- 2.10 VOLUMETRIC SHRINKAGE**
- 2.11 SHORE HARDNESS**



2.1 INTRODUCTION

# **BEYOND THE LAB: APPLICATION OF BONDING AND SIMULATION DATA**

## A COMMITMENT TO GLOBAL QUALITY STANDARDS

Determining the specific needs of an application to enable selection of an appropriate adhesive requires strict adherence to international testing standards. Our accredited testing facilities and technical experts can measure and interpret detailed test data, providing customers with tailored guidance according to the desired performance and specification requirements.

## THE VALUE OF PHYSICAL AND MECHANICAL SIMULATION DATA

In-depth application knowledge through testing enables a greater understanding of the behavioral properties of adhesives and how they are likely to perform in real-world conditions. Putting our adhesives through a wide range of tests and lab simulations provides a wealth of data that can be used in many applications.

In-depth application knowledge through testing enables a greater understanding of the behavioral properties of adhesives.

Understanding bond performance through mechanical and physical testing as well as numerical simulation provides our technical experts with fast and accurate process and performance data. Applying this knowledge in development and manufacturing offers invaluable insight to select the correct product for an application and achieving optimum bond performance.

## ADHESIVE INNOVATION THROUGH CONTINUOUS EXPLORATION

At Huntsman, we pride ourselves on our ability to explore what is possible beyond our business today. Our curiosity and commitment to delivering unrivaled quality standards and exceptional product performance drive our passion to advance the application of available chemistries. With state-of-the-art testing facilities and greater access to complex data, our testing and simulation capabilities remain an important differentiator in designing and delivering adhesives that will address the current and future challenges of our customers.

Discover our Material Models



# ASSESS A MATERIAL'S STRENGTH AND RIGIDITY

## ISO 527-7

Tensile properties are determined by applying the ISO 527-7 test standard.

### Testing and simulation of tensile properties

Behavioral properties of adhesives exposed to variable stresses and their ability to withstand strain without breaking are vital when determining the most suitable adhesive for an application.

Tensile testing is designed to assess the strength of a material under load, as well as the strain (elongation) that occurs in the material as it is loaded.

The results obtained from tensile testing provide information on the strength, stiffness and deformation at rupture of a material under a longitudinal stress.



**Assess the resistance of  
a material under tensile testing**

[▶ Watch the video](#)



## TESTING PROCEDURE

At Huntsman the tensile properties of an adhesive are principally determined using the ISO 527-2 test standard. The test is conducted by placing cast or machined adhesive specimens in the grips of a universal testing machine and applying increasing load at a constant rate until specimen failure.

A relatively slow rate is used to determine the overall material stiffness, known as Young's modulus, followed by a more rapid rate to obtain ultimate tensile strength (UTS) and fracture elongation. An extensometer is used to determine elongation and tensile modulus.

## TEST PARAMETERS

Specimens are either molded to the chosen dimensions or machined from cured products, such as moldings or cast sheets.

The test specimens are so-called dog-bone geometries: either Type 1B (4 mm thick) or Type 5A (2 mm thick). Selection depends on the specimen preparation method and flexibility of the material. A minimum of five specimens are tested for each required orientation.

The speed of testing of the specimens will influence the results.

For ISO 527-2, recommended test speeds are:

- 5 mm/min for elongation < 100%
- 20 mm/min for elongation > 100%

## DATA PROVIDED

Measuring tensile properties provides the following parameters:

- **Tensile strength** - the amount of force that can be applied to a specimen before stretches irreversibly or breaks (in MPa).
- **Tensile (Young's) modulus** - the amount that a specimen stretches in response to an applied stress (in MPa).  
**Young's modulus is a measurement of the material's stiffness.**
- **Elongation** - the increase in specimen length at the point of yield or failure divided by the original length (in %).  
**Greater elongation indicates a more flexible material.**

## Tips for modeling and simulation

The following points should be considered when using tensile test results in numerical modeling

- The model should take into account the temperature dependence of both elastic and plastic parameters.
- For simulation of elasto-plastic behavior the entire stress-strain curve at the given temperature should be employed. When modeling, note that the total elongation at break in tensile test reports includes both elastic and plastic components.
- For calculation of stress-based failure criteria, the tensile strength parameter should be extracted from the tensile test at the corresponding temperature.
- Potential strain rate effects on the loading response should be considered in the stress analysis.

## 2.3 POISSON'S RATIO

# MEASURE DIMENSIONAL CHANGE UNDER LOAD

## ISO 527-2

Poisson's ratio is determined by applying the ISO 527-2 test standard.

The Poisson's ratio measures the degree of change in length and width of a material as it is stretched in a longitudinal direction.

### Testing and simulation of Poisson's ratio

When an adhesive specimen is stretched in a longitudinal direction, it tends to get thinner laterally. The measurement of the relationship between how far a material is stretched and how thin it gets during stretching is an invaluable metric that helps product development teams.

The Poisson's ratio is primarily used by engineers to identify exactly how much material can be stretched or compressed before it fails. This is commonly used in designing new structures because it allows engineers to consider the expected dimensional changes of a given material when under load.



## TESTING PROCEDURE

Poisson's ratio measurements are made according to the ISO 527-2 tensile test method. The tensile test is performed by placing adhesive specimens in a universal testing machine loading until failure, or until irreversible strain occurs (plastic deformation). For practical purposes, strain is defined as deformation of a solid due to an applied stress.

A test speed between 5 and 10 mm/min is applied for determining the Poisson's ratio value using a special bi-axial extensometer.

## TEST PARAMETERS

Specimens are either molded to the chosen dimensions or machined from cured products, such as moldings or cast sheets.

The test specimens are so-called dog-bone geometries: either Type 1B (4 mm thick) or Type 5A (2 mm thick). Selection depends on the specimen preparation method and flexibility of the material. A minimum of five specimens are tested for each of the required direction.

## DATA PROVIDED

**The Poisson's ratio is a measurement of transverse strain divided by axial strain, expressed as:**

$$\nu = - \epsilon_t / \epsilon_l$$

**where  $\nu$  is the Poisson's ratio,  $\epsilon_t$  is the transverse strain and  $\epsilon_l$  is the longitudinal or axial strain.**

It is defined as the negative ratio of the relative contraction strain (transverse, lateral or radial strain) normal to the applied load - to the relative extension strain (or axial strain) in the direction of the applied load (dimensionless ratio).

A high Poisson's ratio means that the material exhibits large elastic deformation, even when exposed to low strain, while a material with a low Poisson's ratio shows little deformation regardless of the magnitude of applied strain.

## Tips for modeling and simulation

When the simulated loading case involves a temperature variation below and above the glass transition temperature of the material, the model should be calibrated with the Poisson's ratio as a function of temperature.

- Poisson's ratio is almost constant in the glassy state and gradually increases to a plateau in the rubbery state. The theoretical asymptotic limit for an unfilled thermoset in the rubbery state is 0.5.
- Smoothstep functions (sigmoid-like interpolation) are typically recommended to model the transition zone between the values in the glassy and rubbery states.
- The transition zone is defined as the temperature range between Tg onset and Peak tan delta when characterized using a DMA measurement.

## 2.4 FRACTURE TOUGHNESS

# ASSESS RESISTANCE TO CRACKS AND FLAWS

ISO  
**13586**

ASTM  
**D5045**

Our internal testing method is based on ISO 13586 and ASTM D5045 standards.

Measurements determine the overall resistance of a material to a load when a fatigue pre-crack is present; the load causes crack extension and crack growth.

### Testing and simulation of fracture toughness

Adhesives in bonded parts are commonly exposed to various degrees of direct and indirect strain. The ability of adhesives to withstand these strains is key to reliable and durable bonding.

The fracture toughness test is a measure of how well a material will resist loads if cracks or flaws form, e.g. from fatigue cycling.

Resistance to crack initiation is expressed as the critical-stress-intensity factor ( $K_{IC}$ ). Additionally the test measures the energy needed to propagate a crack, expressed as the critical strain energy release rate ( $G_{IC}$ ).

The two values give a good indication of how tough or damage tolerant the material is - with higher values indicating higher toughness.

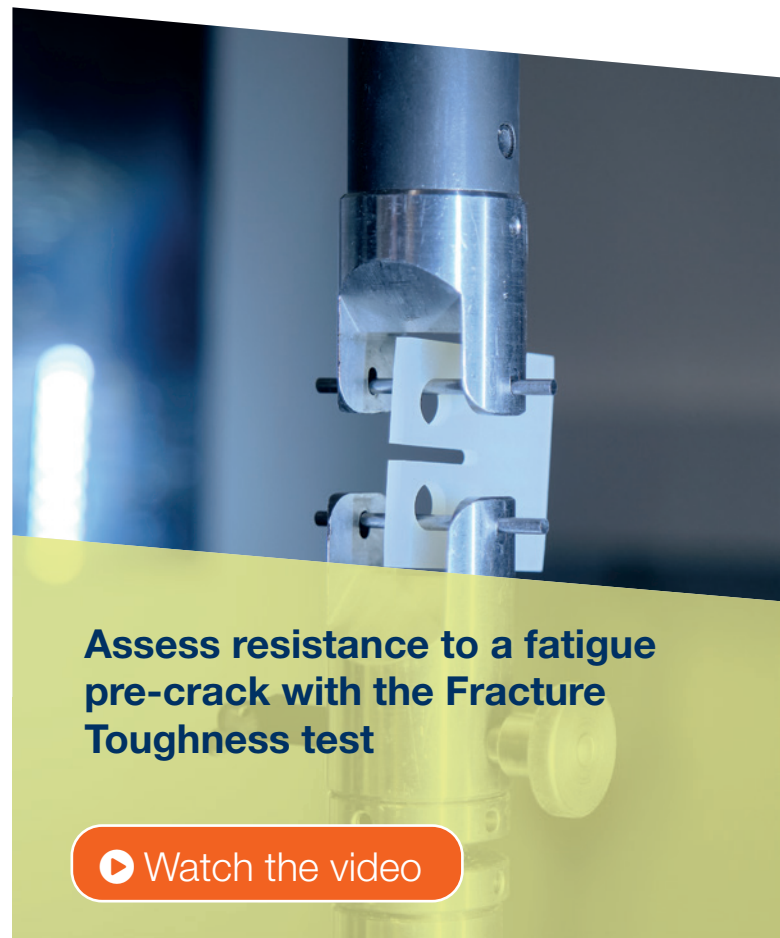

**Assess resistance to a fatigue  
pre-crack with the Fracture  
Toughness test**

[▶ Watch the video](#)

## TESTING PROCEDURE

Testing according to ISO 13586 and ASTM D5045 may be sufficient to give an indication of a material's fracture resistance. However, Huntsman employs an extended method which maps crack propagation during testing. This offers greater insight into material behavior.

Our internal test method is based on the ASTM D5045 and ISO 13586 standards. The fracture toughness test is performed by placing specially pre-cracked test specimens in a universal testing machine and loading until failure, generally at 1 mm/min.

In addition to the standard method, optical crack tracing (OCT) is conducted using a camera to monitor crack length via digital image analysis. This information is combined with the classical stress data to give a complete resistance curve (R-curve).

The OCT method was developed by Fraunhofer IAP, PYCO Research Institution and LaVision GmbH.

## TEST PARAMETERS

The fracture toughness test employs compact tensile (CT) specimens, which are milled with a CNC-milling machine according to the ISO 13586 standard.

A special pre-crack is then generated using a fine blade prior to testing.

At least three specimens are tested; specimen sizes are 35 mm x 35 mm x 4-6 mm (width x length x thickness).

## DATA PROVIDED

Conventional tests methods provide only single values for the critical stress intensity factor ( $K_{1c}$ ) and critical strain energy release rate ( $G_{1c}$ ).

**Our internal method means that full curves can be plotted for K1 and G1 values over the course of the test (R-curve).**

**A complete R-curve is considered a more robust way to determine crack propagation, offering a reliable insight into the material behavior.**

## Tips for modeling and simulation

In this type of simulation, cohesive crack growth is modeled by implementing the so-called traction-separation relation, which is defined by relating the traction (stress) in the adhesive to the separation (displacement) of the adhesive joint in the area where a crack initiates and grows.

- In cohesive damage models, crack initiation is related to the cohesive strength. The area under the traction-separation curve represents the critical energy release rate as new crack surfaces form. The results of OCT test can be used to calibrate the energy dissipation parameters, including the R-curve effects in the CZM simulation.
- For application of OCT test results in cohesive zone modeling (CZM), the potential influence of parameters such as temperature, load rate and loading mode (opening / shearing of crack faces in the adhesive layer) should be considered.

# PREVENT FAILURE FROM THERMAL STRESSES

## ISO 11359-2

Thermal expansion is determined by applying the ISO 11359-2 test standard.

Understanding the relative expansion/contraction characteristics of two materials in contact is critical to understand potential failures.

### Testing and simulation of thermal expansion

Most materials expand with increasing temperature, leading to changes in dimensions. When two materials with different thermal expansion behavior are in contact, such as an adhesive and adherend, warping or internal stress can occur, even leading to joint failure.

Coefficient of Linear Thermal Expansion (CLTE) testing is designed to measure the rate at which a material expands or contracts over a temperature range. CLTE is commonly used for design purposes and can determine if failure by thermal stress is likely to occur.

This is of particular interest to application areas such as the automotive and aerospace sectors where the thermal environment experiences constant change.



## TESTING PROCEDURE

At Huntsman, thermal expansion properties are measured using the ISO 11359-2 test standard. The test is performed by placing the material into a holder with one end in contact with a push-rod.

The sample and holder are enclosed within a precision temperature chamber and the sample subjected to a program of heating, cooling or isothermal conditions. Linear dimensional change: expansion or contraction of the sample, is measured using a very accurate displacement sensor.

Measuring thermal expansion in this way provides the Coefficient of Linear Thermal Expansion (CLTE) over a range of temperatures and can give insight to key material changes such as glass transition.

## TEST PARAMETERS

The standard sample is a milled rectangular specimen with dimensions of 50mm x 4 mm x 4 mm (Length x Width x Thickness).

The ends of test specimens must be precisely milled to ensure that they are parallel. A minimum of two test specimens are required for testing from each sample.

## DATA PROVIDED

The Coefficient of Linear Thermal Expansion is the fractional linear change per degree change in temperature. It describes how the size of an object changes with a change in temperature. Lower coefficients describe lower propensity for change in size.

**CLTE is calculated using the following equation:**

$$CLTE = (L_1 - L_0) / (L_0 * \Delta T)$$

**where  $L_0$  is the initial length of the sample at room temperature,  $L_1$  is the length of the sample at temperature T and T is in kelvin.**

## Tips for modeling and simulation

Coefficient of Linear Thermal Expansion (CLTE) is an essential data input for simulation of thermal cycle as well as residual stress effects.

- Such a simulation inherently involves a coupled analysis of heat transfer together with solid mechanics and requires definition of a reference temperature (stress free state) where the structure is at the equilibrium.
- The CLTE data can be imported in a finite element software by assigning the different CLTE values below and above the glass transition temperature (secant method) or alternatively by introducing the pointwise CLTE values as a function of temperature in tabular manner (tangent method).

# PREDICT THERMAL PROPERTIES OF AN ADHESIVE MATERIAL

## ISO 6721-7

Glass transition temperature is measured with DMA using the ISO 6721-7 standard.

Glass transition temperature ( $T_g$ ) is a measurement of the temperature range where a material changes from a hard glassy state to a soft flexible state.

### Testing and simulation of glass transition temperature

Glass transition temperature ( $T_g$ ) is often measured in terms of material stiffness, or modulus, and may also be referred to as the primary relaxation.

The glass transition temperature of a thermoset polymer material may vary widely, depending on factors such as state of cure, thermal history and moisture content.

Testing the  $T_g$  of an adhesive material helps ensure that it is suitable for a given application and that it is correctly cured. Some adhesives are designed to operate below their glass transition temperature, i.e. in a rigid state, while others are used above their  $T_g$ , in an elastomeric or rubbery state.





## TESTING PROCEDURE

The glass transition temperature is measured with various techniques, but Dynamic Mechanical Analysis (DMA), e.g. by the ISO 6721-7 method, is a sensitive and reliable technique.

A specimen of known geometry is subjected to torsional oscillation with a constant frequency (usually 1 Hz) whilst being heated at a constant rate. The instrument applies a constant stress and the resulting strain is recorded.

A DMA graph shows the variation in response of the adhesive with changing temperature. The storage modulus ( $G'$ ) and loss modulus ( $G''$ ) are indicated.

The  $T_g$  values commonly reported from DMA measurement are:

- $T_g$  onset - from the inflection of the storage modulus curve
- $T_g$  - from the peak of the tan-delta ( $\tan\delta$ ) curve

## TEST PARAMETERS

Test specimens are in the form of rectangular bars or cylindrical rods. The width and thickness of the bars and the diameter of the rods must not vary along the specimen length by more than 2% of a mean value.

At Huntsman, standard test specimens are milled rectangular bars measuring 50 mm x 10 mm x 2 mm.

## DATA PROVIDED

As polymers are heated, molecules begin to move in the material, leading to a number of transition points. Below the  $T_g$ , the amorphous polymer has a lower heat capacity as molecules are relatively static. Above the  $T_g$ , the rubbery, flexible polymer has a higher heat capacity as molecules become mobile.

DMA is effective in separating and measuring the elastic and viscous components of a polymer material's behavior:

- **Storage modulus  $G'$**  - shows the elastic behavior of the material (in Pa)
- **Loss modulus  $G''$**  - shows the viscous behavior of the polymer (in Pa)
- **Loss factor** -  $\tan\delta$  is the ratio between the loss and storage moduli (dimensionless number).

## Tips for modeling and simulation

DMA measurement is a robust method to capture the continuous temperature dependence of a material's elastic behavior for finite element simulations, serving as a shape function for elastic components over temperature.

- The measurements of dynamic shear modulus by DMA can be linked to the elastic modulus and Poisson's ratio as follows:  $G = E / 2(1+\nu)$
- Note that the measured  $T_g$  values depend on the timescale of the deformation. While DMA is typically performed at 1 Hz,  $T_g$  values at higher frequencies could shift to higher temperatures.
- Investigation of such sensitivity can be performed by performing frequency sweep experiments by DMA and application of WLF type analysis.

## 2.7 LAP SHEAR STRENGTH

# EVALUATE PERFORMANCE & DURABILITY

## ISO 4587

Lap shear strength is measured according to the ISO 4587 test standard.

Understanding the amount of shear force that can be exerted on a lap joint before failure occurs is an important parameter for product selection and qualification.

### Testing and simulation of lap shear strength

Shear force remains one of the most common stresses that a bonded joint can face during service, especially in structural bonding applications. Long-term performance is a critical characteristic of any adhesive and measuring shear strength is a favored method for many industries to monitor this.

Lap shear strength is influenced by adhesive strength, but also by surface preparation of the joint and environmental conditions. Lap shear testing may be used to give an indication of:

- **Strength of an adhesive**
- **Surface preparation of the bond area**
- **Influence of bonding conditions such as cleaning, humidity and cure temperature**
- **External factors such as chemical contamination or incorrect storage of the adhesive**

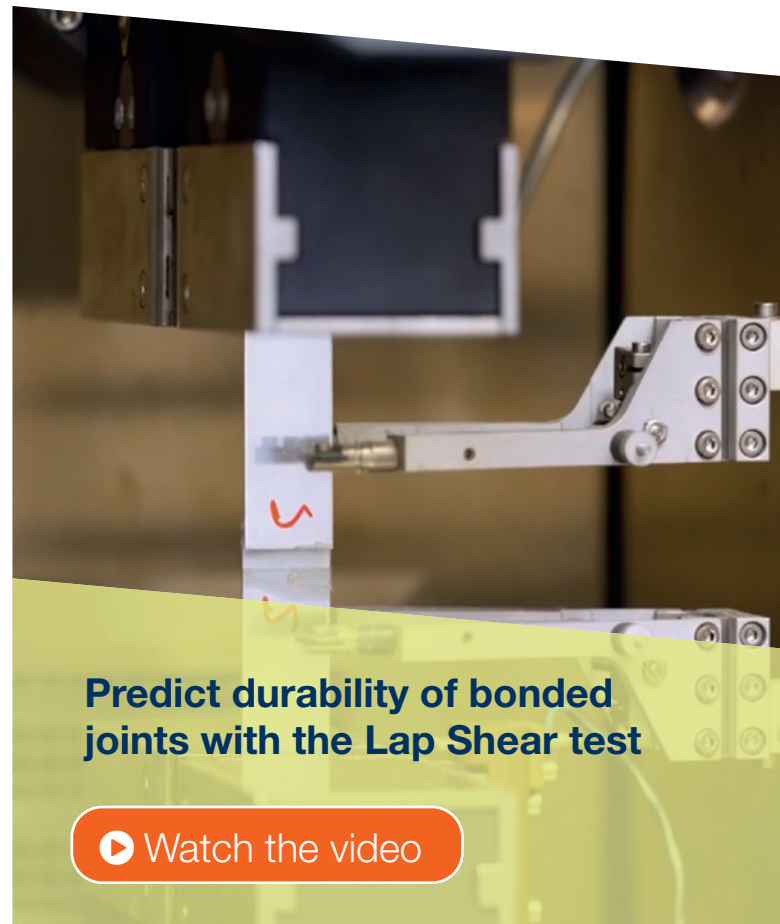

**Predict durability of bonded  
joints with the Lap Shear test**

[▶ Watch the video](#)

## TESTING PROCEDURE

Huntsman testing adheres to the ISO 4587 standard. This international standard requires that the lap shear test is performed by stressing a single-overlap joint between two rigid adherends in shear mode by the application of a tensile force parallel to the bond line.

The specimen is installed symmetrically in the grips of a tensile testing machine. A shim may be used in the grips to ensure that the applied force is perfectly aligned with the adhesive bond.

Specimens are subjected to a tensile stress and the applied force versus axial displacement is measured. The machine operates at a constant test speed, which ensures that the bonded joint fails in a defined period. The resulting (lap shear) strength is then determined.

## TEST PARAMETERS

For testing of structural adhesives, Huntsman commonly employs sandblasted aluminum 5754 substrates (adherends). Two 25 mm x 100 mm substrates are bonded together with a 12.5 mm adhesive overlap.

The ISO 4587 standard recommends that at least 5 bonded specimens are tested.

## DATA PROVIDED

Tested substrates are examined to determine if failure was adhesive, whereby the adhesive material separates from the adherend, or cohesive, where the adhesive ruptures within itself. In some cases, both failure modes are present and the area of each mode is estimated. Test data is reported as:

- **Load at failure (in N)**
- **Shear strength at failure (in MPa)**
- **Type of failure (cohesive or adhesive)**
- **Percentage of failure mode (cohesive vs adhesive)**

## Tips for modeling and simulation

Lap shear test results can serve as input for structural joint analysis in different manners depending on the type of failure.

- In case of cohesive failure, representing the cohesive shear strength parameter and in case of adhesive failure, serving as an input parameter for failure criterion of the interface.

## 2.8 T-PEEL STRENGTH

# MEASURE ADHESIVE BONDING STRENGTH

## ISO 11339

T-peel is determined by applying the ISO 11339 test standard.

### Testing and simulation of T-peel strength

Understanding how much force is required to progressively separate two bonded, flexible adherends provides engineers with a direct measure of the adhesive bond strength in a bonded joint.

Quantifying the peel resistance of an adhesive provides insights for product and process optimization and may form part of a product qualification or specification.

The T-peel strength test determines precisely the degree of stress that must be applied in a peeling mode to initiate and maintain a specified rate of adhesive failure.



## TESTING PROCEDURE

The test method determines relative peel resistance of adhesive bonds between flexible substrates by means of a T-type specimen. The term T-peel refers to shape formed when the ends of the two flexible substrates are placed into the testing machine grips prior to testing.

When measuring the average force required to separate two bonded materials, strength is calculated at a constant speed and rate. This is then divided by the average force required during the test per unit width of the bonded samples.

When carrying out the T-peel test on a bonded flexible-to-flexible substrate assembly, force is applied to the unbonded ends of substrates. The angle between the bond line and the direction of applied force is not fixed. Each unbonded end of the T-shaped specimen is clamped in the grips of the test machine, taking care that it is correctly aligned to distribute force evenly across the width of the bondline.

Adherends are separated at a steady rate so that separation occurs progressively along the bond line. For aluminum adherends, the test standard stipulates a separation rate of 100mm/min. The force applied is recorded versus the distance of separation. The test is continued until at least 150 mm of the adhesive bond line is separated.

## TEST PARAMETERS

Specimens are prepared either individually or cut from bonded panels. Test specimens consist of two flexible sandblasted aluminum adherends, prepared and bonded together. The preferred width is 25 mm according to ISO 11339 standard.

A minimum of 5 specimens is recommended.

## DATA PROVIDED

The T-peel strength provides the average peel force, as well as maximum and minimum peeling forces during testing of an adhesive assembly.

## Tips for modeling and simulation

While T-peel test results do not typically serve as a direct input for finite element simulation of adhesive joints, this test can indirectly serve simulations like cohesive zone modeling (CZM), either as a measure for model validation or as an experimental target value for an inverse calibration method.

An inverse calibration method involves parametric simulation of the experiment and iterating the CZM parameters until the simulated results match the measured data.

# ASSESS THE EFFECT OF CURING

## ISO 1183-3

Cured density is determined by applying the ISO 1183-3 test standard.

Product engineers must consider adhesive density in overall part design. Cured density is also further used in shrinkage calculations for reactive adhesives.

### Testing and simulation of cured density

Density is the measure of a material's mass per unit volume. Cured density is measured on an adhesive after the hardening (curing) process.

Density measurements can be used to evaluate uniformity of material quality or to indicate issues such as the presence of voids in bonded parts.

Characterizing density of an adhesive after the curing process offers key information which may be used in further evaluations, such as volumetric shrinkage.



## TESTING PROCEDURE

Huntsman follows the ISO 1183-3 test standard for density measurement of solids. This method employs a gas pycnometer instrument for determination of density by measuring the change of gas pressure within the instrument upon introducing a specimen at a given temperature.

The precise volume of the specimen is calculated using the change of gas pressure within the pycnometer, and this together with the mass of the specimen enables the density to be calculated. This method of volume measurement removes the effect of any large voids or irregularities in the specimen.

## TEST PARAMETERS

Test specimens are based on the ISO 1183-3 standard and may consist of powder, granules, pellets or flakes. Other materials may be cut to any shape convenient for the size of the pycnometer cell used.

Huntsman testing commonly employs a 4mm cubed specimen. It is important to avoid changes in density resulting from compressive stresses on the material during cutting or specimen preparation.

A minimum of two specimens are tested using this method and temperature is precisely controlled.

## DATA PROVIDED

**Density (g/cm<sup>3</sup>) is calculated using the following equation:**

$$\rho^T = m_{\text{app}} / V$$

**where  $\rho^T$  is the mass per unit volume of a material at a given temperature T,  $m_{\text{app}}$  is the mass of a body obtained by measuring its weight using a balance and V is the volume of a body in three-dimensional space without pores.**

# PREDICT THE IMPACT OF VOLUME CONTRACTION

ISO  
**1183-3**

ISO  
**3521**

Our testing method is based on the ISO 1183-3 and ISO 3521 standards.

Volumetric shrinkage testing is an important characteristic that enables engineers to understand and prevent part deformation and internal stresses that can lead to cracks and long term failure of a bonded assembly.

## Testing and simulation of volumetric shrinkage

Optimization of the curing process is paramount for the strength of high quality adhesives. Reactive adhesives typically shrink (contract) during the curing process as chemical bonds are formed. The extent to which a reactive adhesive shrinks will depend on the chemical composition, the cure temperature and the cure speed.

Measurement of an adhesive's density before and after the curing process enables the volumetric shrinkage to be calculated.

This enables engineers to predict the change in bond line thickness for an adhesive with a given set of cure conditions, offering key information regarding internal stress and deformation (warping) in bonded parts.





## TESTING PROCEDURE

Huntsman's internal standard for determining volumetric shrinkage relies on accurate measurement of an adhesive's density before and after the curing process.

- Step 1 assesses the density of the uncured system in liquid or paste form
- Step 2 assesses the density of the cured system after the curing process and conditioning

Huntsman follows the ISO 1183-3 test standard for density measurement of solids, but additionally applies the method to liquid and paste materials. This uses a gas pycnometer instrument for determination of density by measuring the change of gas pressure when a specimen is introduced.

The cure conditions of an adhesive will greatly influence the resulting shrinkage, so it is key that measurements of the cured density are carried after applying the cure schedule for the intended application or according to specific customer requirements.

## TEST PARAMETERS

For the uncured state, the liquid adhesive components are conditioned at the measurement temperature before being mixed and measured immediately to avoid advancement of the curing reaction. For the cured state, a cured plate is prepared in a mold and 4mm cubes cut for testing. A minimum of two specimens are measured for each state.

## DATA PROVIDED

The overall volume shrinkage is calculated as a percentage of the change in the density before and after curing. A positive value represents volume shrinkage while a negative value represents volume expansion.

**Volume shrinkage is calculated using the following relationship:**

$$\text{Shrinkage \%} = (D_2 - D_1) \times 100 / D_1$$

**where  $D_1$  is density when uncured and  $D_2$  is density after curing.**

## Tips for modeling and simulation

Volumetric shrinkage is an essential data input for the simulation of process induced stresses and deformation.

Volumetric shrinkage due to adhesive contraction (shrinkage) during the curing process can lead to residual stresses and deformation in assembled parts.

Simulation of residual stresses involves concurrent cure kinetics, heat transfer and mechanical analysis. Robustness of such a model relies primarily on the accuracy of the input data describing the volumetric contraction and evolution of elastic modulus as a function of the degree of adhesive cure during the curing process.

# MEASURE A MATERIAL'S HARDNESS

ISO  
**868**

Shore hardness is determined in accordance with the ISO 868 standard.

Shore hardness testing is a useful measure to quickly compare flexibility of different materials.

## Testing and simulation of Shore hardness

Shore testing is an accurate way to measure the hardness of elastomeric and plastic materials like adhesives.

The two Shore hardness scales commonly used when comparing adhesive materials and other plastics are Shore-A for very soft to soft (elastomeric) materials and Shore-D for semi-rigid and hard plastics.

Shore hardness is measured with an instrument that presses a specially shaped metal rod or cone into the material being tested. Higher numbers on the scale indicate a greater resistance to indentation and thus a harder material.



## TESTING PROCEDURE

Huntsman adheres to the Shore hardness test standard ISO 868. The measurement is achieved through use of a durometer; an instrument which presses a special hardened indenter directly into the cured adhesive with a set force and measures the depth indented.

The shape of the indenter, the force applied to it and the duration of its application influence the results and must all be kept constant for accurate measures.

The Shore hardness method measures the indentation resistance of adhesives based on the depth of penetration of a conical indenter.

Two types of durometer are commonly applied:

- **Shore durometer type A (for softer adhesives) are used when type D results are less than 20**

Press force:  $12.5 \pm 0.5$  N

Max. spring load: 8.065 N

Indenter: diameter  $0.79 \pm 0.03$  mm

- **Shore durometer type D (for harder adhesives) are used when type A results are greater than 90**

Press force:  $50.0 \pm 0.5$  N

Max. spring load: 44.500 N

Indenter: radius  $0.10 \pm 0.01$  mm

## TEST PARAMETERS

Huntsman testing requires test specimens based on cast plates of 50 mm x 50 mm x 6 mm of cured adhesive. A minimum of 5 specimens are tested.

## DATA PROVIDED

Two types of Shore measurement results are used: instantaneous hardness is when there is no delay between applying the indenter and measurement, while delayed hardness employs a specified time between indenter application and the reading (the time delay must be stated, typically around 5-10 seconds).

**The hardness of an adhesive is stated in units of the Shore scale being employed (Shore A or Shore D). Values are based on the penetration depth of the indenter, ranging from 0 (full penetration) to 100 (no penetration).**

# 3.0

# SURFACE PREPARATION AND PRETREATMENTS

Bonding performance is always a combination of multiple factors, including mechanical, chemical and physical interactions.

Bonding is an interfacial phenomenon, as the adhesive forms an interface with the substrates to be bonded.

The surface conditions of the parts to be bonded are therefore a critical factor in achieving a dependable quality bond.



### **3.1 INTRODUCTION**

General considerations  
Why use surface preparation?  
Test for a clean bond surface

### **3.2 SURFACE PREPARATION METHODS**

Degreasing methods  
Abrading methods  
Special pretreatments for metals  
Special pretreatments for plastics and composites

### **3.3 APPROPRIATE SURFACE TREATMENT**

Preparing metals  
Preparing plastics and composites  
Preparing other industrial materials

### **3.4 ANNEXES**

Etchant compositions

# GENERAL CONSIDERATIONS

Proper surface preparation is essential for optimum adhesion between structural materials bonded with ARALDITE® adhesives.

Huntsman industrial adhesives are high performance products which adhere firmly to most materials. High strength bonds can be obtained after removal of grease and loose particles, e.g. rust, from the surfaces to be joined. However, when maximum strength and long-term durability are required, a more thorough mechanical or chemical surface pretreatment is highly recommended.

The type of surface preparation to be carried out prior to bonding depends on the required performance level (Figures 18, 19 and 20), the service conditions of the assembly and economic considerations (ratio cost vs benefit).

**FIG. 18 EFFECT OF DIFFERENT SURFACE PREPARATIONS ON BOND STRENGTH DURING WATER IMMERSION FOR AN ALUMINUM ASSEMBLY BONDED WITH A ONE-COMPONENT EPOXY ADHESIVE**

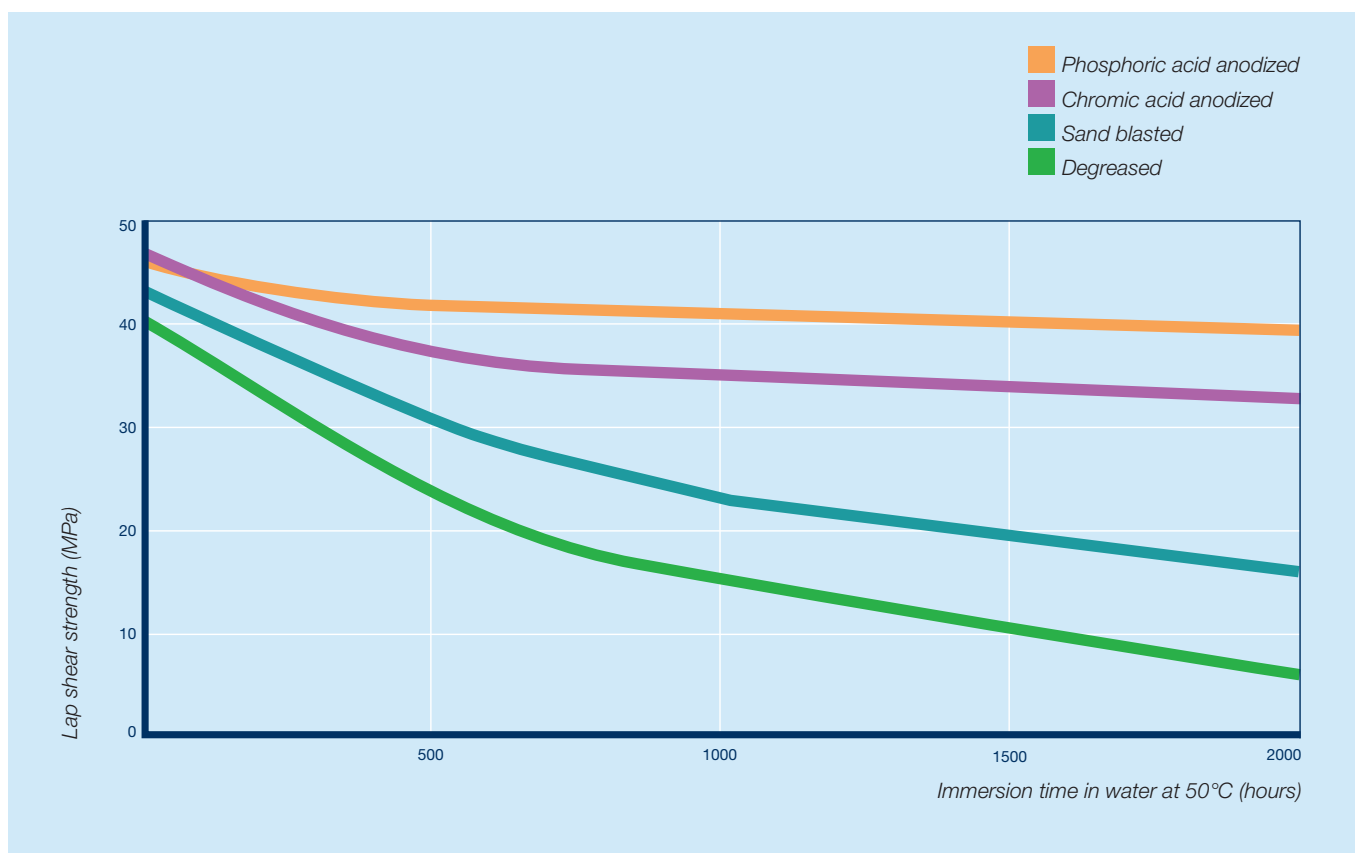

### 3.1 INTRODUCTION

# GENERAL CONSIDERATIONS

**FIG. 19 EFFECT OF PLASMA SURFACE TREATMENT ON PLASTIC BONDING**

(Two-component toughened epoxy adhesive - Two-component polyurethane adhesive)

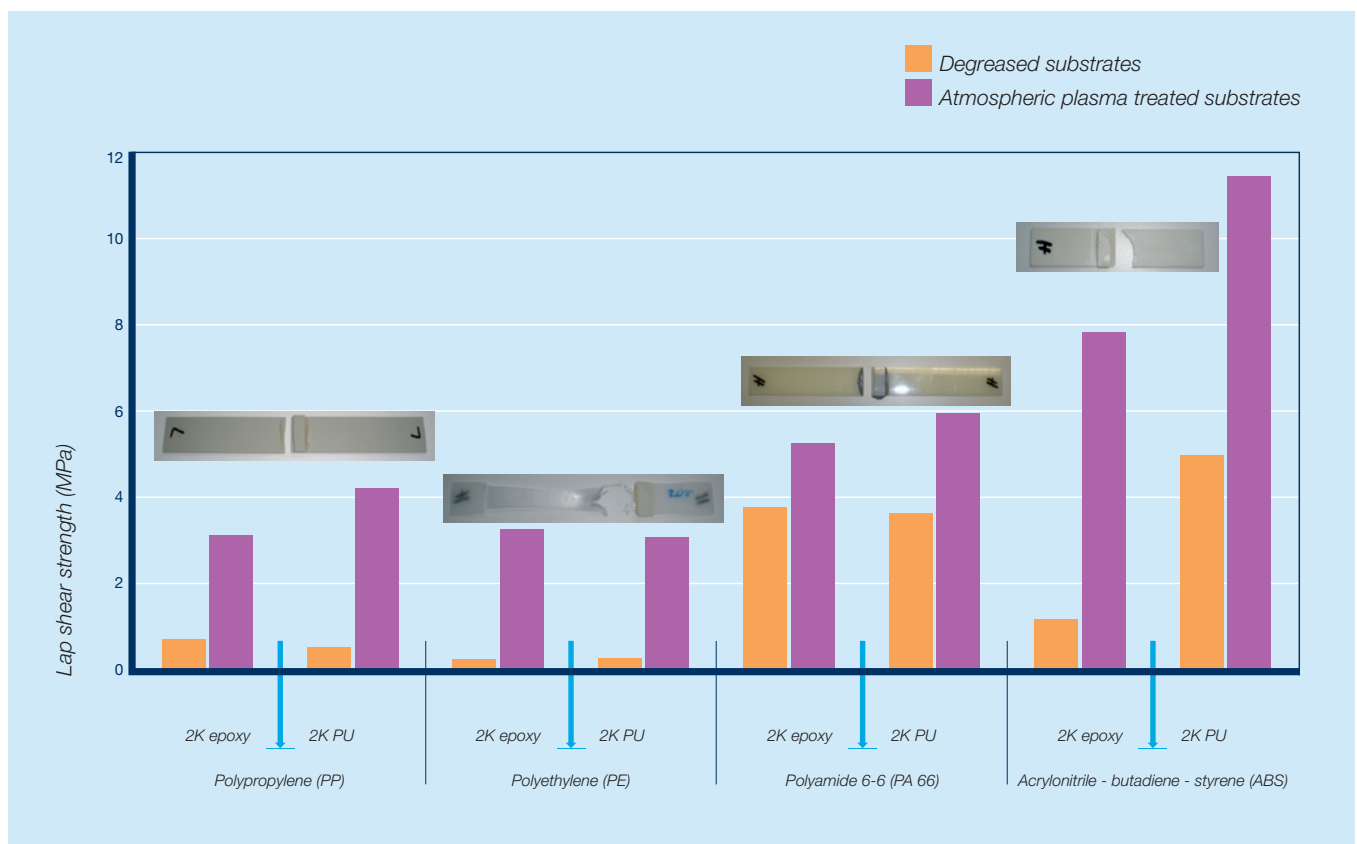

Note: systematic substrate failure on plasma-treated specimens



**FIG. 20 EFFECT OF SURFACE PREPARATION ON AGEING PERFORMANCE OF ALUMINIUM BONDED WITH TWO-COMPONENT TOUGHENED EPOXY ADHESIVE**

*(Wet cataplasma aging)*

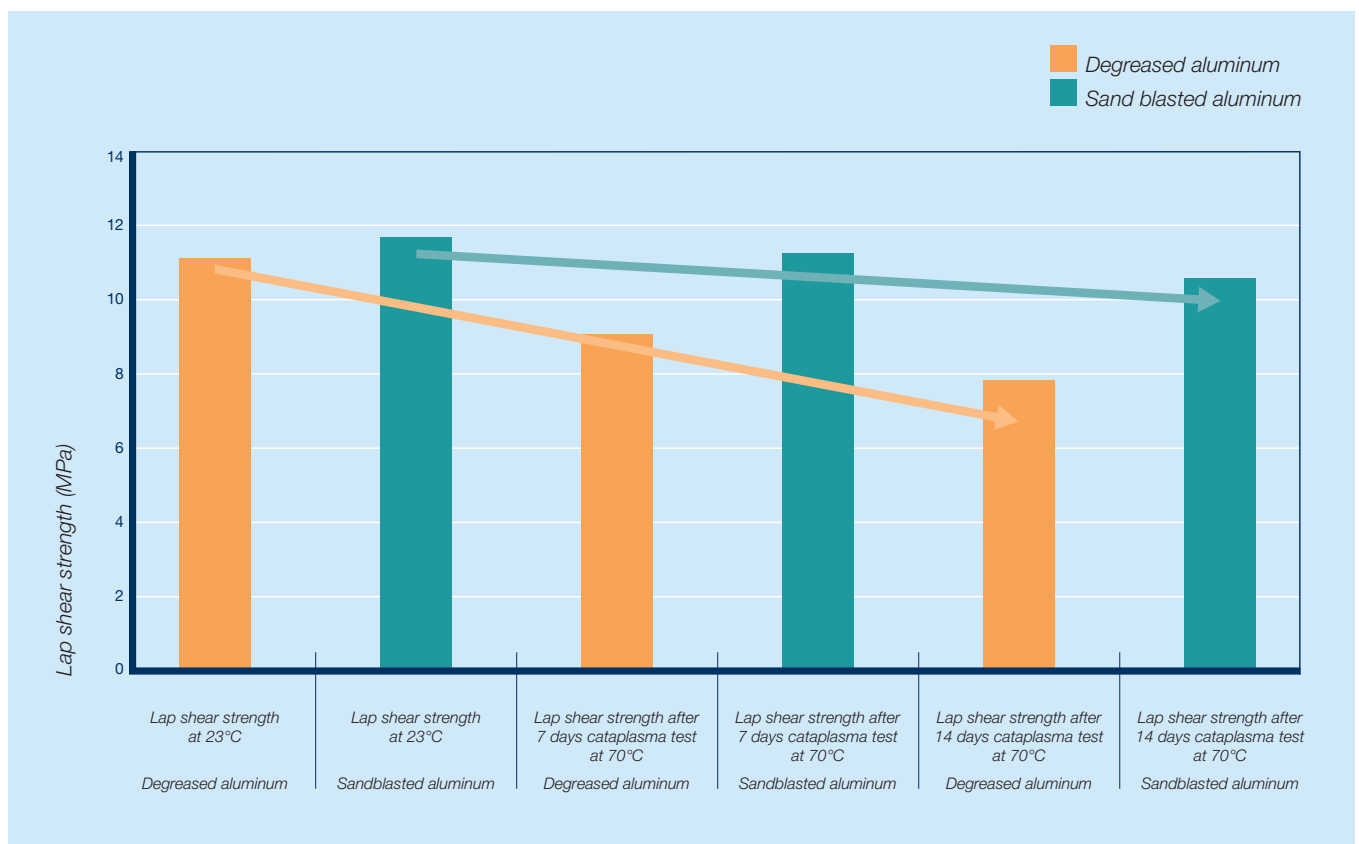

*Cataplasma test: 70°C with high humidity + thermal shock at -20°C*

# WHY USE SURFACE PREPARATION?

In order to ensure an optimum wetting and a satisfactory adhesion on the substrate, a thorough surface preparation is required:

- To remove contaminants and/or low cohesion layers (oxides)
- To offer a clean surface for bonding
- To increase the bonding area
- To ensure that the substrate surface is fully wetted by the adhesive (e.g. by increasing the surface energy of the substrate)

Care must be taken to avoid contaminating the surfaces during or after pretreatment. Contamination may be caused by skin contact (clean gloves should be worn), using contaminated cleaning rags, by oil contaminated abrasives, by substandard degreasing or chemical solutions.

Contamination may also be caused by other work processes taking place around the bonding area. Oil vapors from machinery, spraying operations (paint, mold release-agent, etc.) and processes involving powdered materials must be particularly avoided.

**Whatever the pretreatment procedure used, it is good practice to bond the surfaces immediately after the pretreatment has been performed i.e. when surface properties are at their best.**

Note: If a delay between pretreatment and bonding cannot be avoided, optimum surface properties may be preserved by applying a suitable primer to the bond surfaces immediately after pretreatment.

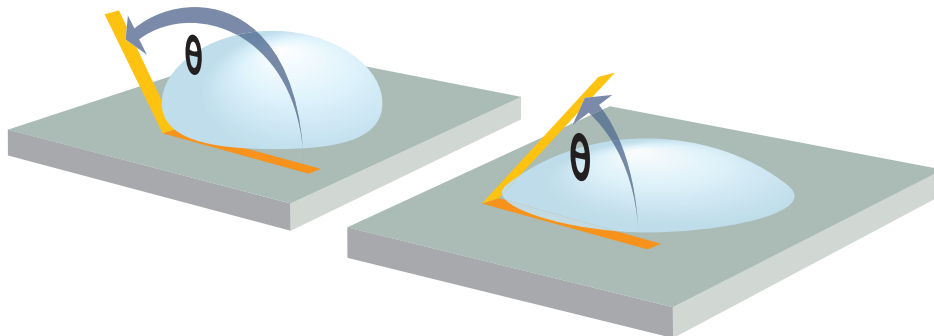

WETTING ANGLES BEFORE SURFACE PREPARATION (LEFT) AND AFTER (RIGHT)

### 3.1 INTRODUCTION

# TEST FOR A CLEAN BOND SURFACE

If a few drops of distilled water applied to a surface spread over it – or if, on drawing the surface from distilled water, the water film does not break up into droplets – then the surface may be assumed to be acceptably free of contamination. Uniform wetting of the surface by distilled water indicates that it will probably be likewise wetted by an adhesive.

It must be borne in mind that certain plastics, even when clean, may not be wetted by distilled water, but will be wetted by suitable adhesives. Furthermore, it should be noted that a satisfactory wetting provides no information with regards to the potential bond strength and durability of the bonded assembly. At most it is a necessary – but not sufficient – requirement for the achievement of high bond strengths.

The surface tension of plastic materials cannot be directly measured and is therefore usually determined indirectly by contact angle methods or using testing inks. Several standard methods have been developed to respond to the different types of substrates being evaluated (see literature, e.g. Adhesives Technology Handbook – W. Andrew Editions).

The water droplet test is a simple method to determine whether the surface to be bonded is clean. It is best suited to metals.

*BAD WETTING*

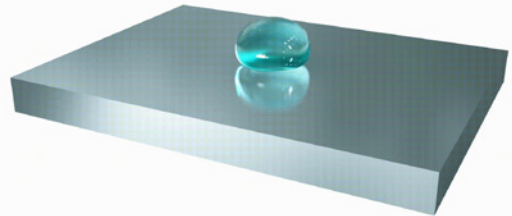

*GOOD WETTING*

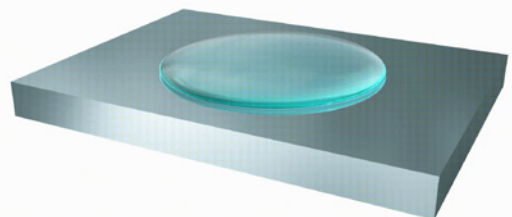

## 3.2 SURFACE PREPARATION METHODS

# DEGREASING METHODS

The removal of all traces of oil, grease or release agents from the surfaces to be bonded is essential. Degreasing by one of the methods given below should be carried out even when the surfaces to be bonded appear clean.

### VAPOR DEGREASING

The parts are suspended in a vapor degreasing unit, using common degreasing solvent such as acetone, methyl ethyl ketone (MEK), ethanol or isopropanol. The unit may include a compartment to enable initial washing in the liquid solvent.

### SOLVENT IMMERSION

Where a vapor degreasing unit is not available, immerse successively in two tanks each containing the same degreasing solvent. The first tank acts as a wash, the second as a rinse. When the solvent in the wash tank becomes heavily contaminated, the tank is cleaned out and refilled with fresh solvent. This tank is then used for the rinse, and the former tank for the wash.

### BRUSH OR WIPE

Brush or wipe the joint surfaces with a clean brush, cloth or lint-free paper soaked in a commercial degreasing solvent. For fine work, cleaning with solvent applied by aerosol spray may be a more suitable alternative; this technique also ensures that the solvent used is perfectly clean. Allow to stand for a minute or two to allow complete evaporation from the joint surfaces. A wide range of proprietary solvent degreasing agents with low hazard ratings are now available. These should be used in accordance with the manufacturer's instructions.



Removal of oil or grease residues is key but should be combined with other surface preparation method for optimal bonding:

- Degreasing only (good)
- Degreasing, mechanical abrasion followed by loose particle removal (very good)
- Degreasing and chemical pretreatment (excellent)



**Want to remove all traces of oil and grease from the surfaces to be bonded?**

[▶ Watch the video](#)

### **ALKALINE DEGREASING**

Alkaline degreasing is an alternative method to detergent degreasing. Sodium or potassium hydroxide, carbonates, phosphates, borates, complexing agents and organic surfactants are all used for this application. This method can be carried out hot or cold, with or without applied electrical current. Thorough washing, and possibly neutralization, is required to remove residual traces of alkaline cleaners. It is recommended to use proprietary products and to follow the manufacturer's instructions for use.

### **ULTRASONIC DEGREASING**

Ultrasonic degreasing may also be employed and is typically used for the preparation of small specimens (by ultrasonic vapour degreasing or solvent immersion).

### **DETERGENT DEGREASING**

Scrub the joint surfaces in a solution of liquid detergent. Non-ionic detergents generally give good results. Wash with clean hot water and allow to dry thoroughly – preferably in a stream of hot air from, e.g. a forced-air heater.

# ABRADING METHODS



Lightly abraded surfaces provide better anchoring to adhesives than highly polished surfaces.

If substrates are abraded, this must be followed by cleaning to ensure complete removal of any dust or particles. Cleaning methods following abrasion:

- Repeat the degreasing operation, degreasing liquids must be clean (good)
- Lightly brush with a clean soft brush (very good)
- Clean the surface with a suitable industrial vacuum cleaner (excellent)

## PLASTICS AND COMPOSITES SURFACES

Remove the top layer of molded plastic surfaces to ensure elimination of all traces of release agent. As with metals, abrasion is in general the best method, but grit blasting is often replaced by sanding, either manually or with a sanding machine. After abrasion, all loose particles must be removed. Use of peel (or tear) plies is often used on composite parts to produce a ready-to-bond surface: peel plies are special fabrics applied on the surface of the composite during molding and peeled off immediately prior to bonding, leaving a roughened, clean surface suitable for bonding.

### NOTE

**Removal of loose particles from plastic surfaces is best carried out by brushing, tack cloths or vacuum cleaning. Since plastics often carry static electrical charge, care is needed to avoid recontamination after cleaning, and parts should be bonded as soon as possible. Use of degreasing liquids on certain plastics may impair the abrasion treatment. Since plastics are poor heat conductors, care must be taken to keep grit blasting or sanding times as short as possible to avoid overheating. For composites pretreatment, cryoblasting may also be used, which employs solid carbon dioxide pellets as the blasting medium. This leaves a clean, abrasive-free surface and avoids heating.**



## METAL SURFACES

Remove surface deposits, e.g. oxidation, corrosion or mill scale, preferably by grit blasting using a suitable abrasive media. For most materials the preferred grits are fused alumina and, less commonly, silicon carbide (ferrous grits such as chilled iron must be restricted to mild steels and cast irons; their use on other metals may promote corrosion). Fused alumina is the most common abrasive for aluminum alloys and stainless steels. Silicon carbide is sharper, but it is more expensive and also more friable. Silicon carbide is used on certain special alloys likely to react adversely with any residual fused alumina at temperatures they may be exposed to under service conditions. The use of silicon carbide may be preferable when the materials to be abraded are either soft or extremely hard.

Choice of grit size depends on various factors: metal to be grit blasted, type of grit blasting equipment, pressure and angle of blast impact, and time of treatment.

Grits from 46 to 120 mesh (350 to 125  $\mu\text{m}$ ) are usually adequate for most applications, however the optimum grit size for specific applications may have to be determined by trials. In general, for soft materials the optimum grit size will be towards the fine end of the range.

If grit blasting equipment is not available or the metal is too thin to withstand blasting treatment, joint surfaces may be cleaned with a wire brush, or with abrasive cloth or paper (alumina or silicon carbide abrasive). Wetting the wire brush – or the abrasive cloth or paper – assists removal of contaminants and reduces dust. Dry, if necessary, and remove all loose particles.

### NOTE

**Painted surfaces should be stripped of paint; otherwise the strength of the joint may be limited by the comparatively low adhesion of the paint to metal.**

# SPECIAL PRETREATMENTS FOR METALS



The surface preparations previously described (degreasing alone or degreasing followed by abrasion and removal of loose particles) is sufficient for most adhesive bonding.

However in order to obtain maximum strength, reproducibility and long-term durability of a bond, a chemical or physical pretreatment may be required. Examples of these special pretreatments are described in this section and some additional details can be found in the annexes.

## ACID ETCHING

The visible surface of any metal substrate is rarely made of pure metal and is far more likely to be a combination of oxides, sulfides, chlorides and other atmospheric contaminants resulting in a surface which is mechanically weak. Acid etching is a well-established method of removing surface oxidation layers, generally weakly attached to the metal surface, and replace them with a strongly bonded layer which is mechanically and chemically compatible with the adhesive. Different acid treatments are applied to different metal adherends, for example, chromic acid for aluminum, sulfuric acid for stainless steel, and nitric acid for copper.

## ANODIZING

Anodizing is used extensively by the aerospace industry as a surface pretreatment for aluminum and titanium alloys. The purpose of anodizing is to deposit a porous oxide layer on top of the oxide layer formed after etching. The porous oxide layer enables adhesive (or primer) to penetrate the pores readily to form a strong bond. To be suitable for bonding, the oxide layer generated by anodization should remain unsealed. Hard anodized aluminum alloy requires stripping either by abrasive blasting or by etching: the hard anodize finish offering only poor bonding.



## APPLICATION OF A PRIMER

Primer application is another form of surface pretreatment mainly used for materials such as metals, glass and ceramics. Generally, the primer is the final stage of a multistage pretreatment process. Some substrates have "difficult to bond" surfaces (e.g. copper), meaning that they are not easily wetted. The primer, which is often a similar composition to the adhesive with additional solvent, readily wets the substrate. Once the adhesive is applied to a chemically compatible surface, it will form a strong bond after curing.

Care must be taken in the preparation of chemical pretreatment solutions, not only because of the handling

hazards, but because incorrect preparation could lead to lower bond strengths compared to no chemical treatment. Time of application is also important: too short an application may not sufficiently activate surfaces, whereas an excessively long exposure to the chemical(s) may result in chemical reaction products which will interfere with adhesion.

Upon completion of a chemical pretreatment, a thorough washing of the surfaces with sufficient clean water is standard practice. For the final rinse, the use of de-ionized (demineralized) water is strongly recommended.



**Want to achieve a good preparation for metals?**

[▶ Watch the video](#)

# SPECIAL PRETREATMENTS FOR PLASTICS AND COMPOSITES



The type of polymer and the manufacturing process used to make the substrates to be bonded may influence the effectiveness of the physical pretreatment.

It is also advisable to test whether the quality of the pretreatment is dependent on the specific treatment time. Acid pretreatment can also be applied to certain plastics, e.g. chromic acid is used to surface treat polyolefins.

## LOW PRESSURE PLASMA

A plasma is formed by applying a high frequency voltage to a gas using electrodes in a low-pressure chamber. If substrates, in particular plastics, are placed in the plasma, their surface energy is increased. A higher surface energy enables full wetting of the substrate surface by an adhesive, forming a strong, durable bond. Different plasmas can be formed, e.g. by argon, ammonia, oxygen or nitrogen gas, making the process suitable for a range of substrate types.

This method is usually preferred for the treatment of small parts with a complex geometry or for parts on which the surface to be bonded is difficult to access.

## ATMOSPHERIC PLASMA

A plasma is created in air at atmospheric pressure (without additional gases), and the beam generated does not have any electrical potential. The benefits of this method are similar to the previous one. This method is usually preferred for larger plane surfaces. The parameters which can influence the quality of the treatment are the exposure time and the distance between the surface and the plasma nozzle.

## FLAME TREATMENT

The effect of a flame treatment is to oxidize the surface layer to produce polar groups; the increased polarity of these groups leads to increased surface energy and thus improved wetting by the adhesive. This method of surface pretreatment has been applied successfully to polyethylene and polypropylene. The parameters which can influence the quality of the flame treatment include type of gas to air (oxygen)-ratio, flow rate, exposure time and distance between flame and substrate.

## CORONA TREATMENT

Under normal atmospheric pressure, a high voltage discharge creates oxygen and ozone molecules which will lead to the activation of the plastic surface by oxidation.

**All these methods have limited stability which can vary from hours to weeks according to substrate.**

**Want to achieve a good preparation for plastics?**

[▶ Watch the video](#)



# PREPARING METALS

Preparation methods for most common metals are shown in the table on the following page.

Engineers wishing to bond materials not covered in this manual should discuss with our technical team.





























Contact

The wide range of individual alloys (and the variety of surface structures caused by heat treatments) within each metal group precludes standardizing on one pretreatment for each.

The following pretreatments are well established, but on occasion a different pretreatment (not described in this manual) may prove more effective. This can be shown only by comparative testing – using materials from the batch of metal components to be bonded and the type of adhesive specified for the work.

Want to achieve a good preparation for metals?

Watch the video

| Substrate   | Preferred pretreatment (state of the art)   | Alternative solution  | Remarks   |
|---|---|---|---|
| Aluminum and alloys non-anodised                        |    |    | Special pretreatment: anodise with chromic or phosphoric acid.  |
| Aluminum and alloys anodised / unsealed                 | None  | None  | Chromic acid or phosphoric acid anodised material has the optimum surface properties for bonding directly after completion of the anodising process. No pretreatment is needed, but the material must be bonded within a few hours after anodising.   |
| Aluminum and alloys hard anodised / anodised and sealed |    |    | Special pretreatment: requires stripping either by abrasive blasting or by etching (annex Etchant 1). The unstripped metal is unsuitable for bonding. Aluminum alloy anodised by the normal chromic acid or sulphuric acid methods and sealed, may be bonded after degreasing and light abrasion. |
| Cadmium   |    |    | Special pretreatment: electro-plate with silver or nickel.  |
| Cast iron   |    | —   | —   |
| Copper and copper alloys                                |    |    | Special pretreatment: etching solution (annex Etchant 2).   |
| Chromium  |    |    | Special pretreatment: etching solution (annex Etchant 3).   |
| Galvanised surfaces                                     | —   | —   | See zinc and zinc alloys.   |
| Gold  |  | —   | —   |
| Lead  |  |  | Special pretreatment: etching solution (annex Etchant 4).   |
| Magnesium and magnesium alloys                          |  |  | Special pretreatment: etching solution (annex Etchant 5).   |
| Nickel and nickel alloys                                |  |  | Etch for 5 seconds in concentrated nitric acid. Wash with clean cold running water, followed by clean hot water, and dry with hot air.  |
| Silver  |  | —   | —   |
| Steel mild  |  |  | Special pretreatment: etching solution (annex Etchant 6).   |
| Stainless steel   |  |  | Special pretreatment: etching solution (annex Etchant 7).   |
| Tin   |  | —   | —   |
| Titanium and titanium alloys                            |  |  | Special pretreatment: etching solution (annex Etchant 8).   |
| Tungsten and tungsten carbide                           |  |  | Special pretreatment: etching solution (annex Etchant 9).   |
| Zinc and zinc alloys                                    |  | —   | Apply the adhesive immediately after surface preparation.   |

 Degreasing

 Abrading

 Special pretreatment

# PREPARING PLASTICS AND COMPOSITES

Most common plastics and composites likely to be bonded are covered in the table on the following page.

Engineers wishing to bond materials not covered in this manual should discuss with our technical team.

Contact

## THERMOSETS

Moldings, castings, laminates and the like can usually be bonded without difficulty. However in order to ensure good bond strength, all surface contaminants (e.g. residual release agent) must be removed from the joint surfaces before the adhesive is applied. The surfaces must be either abraded, e.g. with emery cloth or sand paper, or they must be cleaned with an organic solvent such as acetone, methyl ethyl ketone (MEK) or isopropanol. Abrading, bead blasting or peel ply is highly recommended for molded parts since their surfaces may otherwise repel the adhesive.

## THERMOPLASTICS





























Although thermoplastics are often difficult to bond, the wide range of Huntsman industrial adhesives provides a solution for many common plastics. Pretreatment, such as plasma, flame and corona discharge, are especially effective for bonding of thermoplastics. Some types of thermoplastic, such as polyethylene and polypropylene, are particularly difficult to bond, and will produce only limited bond strength even after surface treatment.

**Want to achieve a good preparation for plastics?**

[▶ Watch the video](#)

**Want to achieve a good preparation for composites?**

[▶ Watch the video](#)

| Substrate                                   | Preferred pretreatment (state of the art)   | Alternative solution  | Remarks   |
|---|---|---|---|
| ABS   |    |    | Special pretreatment: etching solution (annex Etchant 10) or plasma treatment.  |
| Cellulose based polymers                    |    | —   | Warm preferably for 1 hour at 100°C and apply the adhesive before the material cools completely down to room temperature.   |
| Composites (fiber reinforced thermosets)    |    |    | Alternatively, design the laminate in such a way that a 'peel ply' of special close-weave fabric is placed at the surface to be bonded. The ply becomes part of the laminate on curing and is 'peeled' off prior to bonding, exposing a roughened, clean bonding surface on the laminate. Special pretreatment: plasma treatment.   |
| Decorative and industrial laminates         |    |    | Special pretreatment: pretreat using corona / plasma treatment.   |
| Polyacetal (POM)                            |    | —   | Special pretreatment: etching solution (annex Etchant 10).  |
| Polyamides (Nylon)                          |    |    | Special pretreatment: pretreat using corona / plasma treatment.   |
| Polyacrylics (PMMA...)                      |    |    | For optimal results, it is recommended to stress relieve the material by annealing. Special pretreatment: plasma treatment.   |
| Polycarbonate                               |    |    | Special pretreatment: pretreat using corona / plasma treatment.   |
| Polyesters (unsaturated thermosets)         |  | —   | See composites (fibre reinforced thermosets).   |
| Polyesters thermoplastic moldings and films |  |  | Special pretreatment: etching solution (annex Etchant 11).<br>Alternative: corona / plasma treatment.   |
| Polyetheretherketone (PEEK)                 |  |  | Special pretreatment: Pretreat using corona / plasma treatment.   |
| Polyimide                                   |  |  | Special pretreatment: pretreat using corona / plasma treatment.   |
| Polyolefin (PP, PE)                         |  | —   | Special pretreatment: pretreat using flame / plasma treatment.<br>Lightly flame treat with a waving motion in an oxidising gas flame until the surface is shiny. Proprietary primers for polypropylene are available which provide an alternative to flame and plasma pretreatments.  |
| Polyphenylene oxide (PPO)                   |  |  | Special pretreatment: pretreat using corona / plasma treatment.   |
| Polystyrene                                 |  | —   | —   |
| Polyurethane                                |  |  | Special pretreatment: pretreat using corona / plasma treatment.   |
| PTFE and similar fluorocarbon plastics      |  | —   | Fluorocarbon based polymers cannot normally be bonded in the untreated condition. There are, however, specialised processes (involving flame oxidation or exposure to dispersions of metallic sodium) for treating the surfaces of fluorocarbon polymers. Pretreated PTFE using such processes is available from various suppliers. |
| PVC   |  | —   | —   |
| SMC / BMC                                   | —   | —   | See composites (fibre reinforced thermosets).   |

 Degreasing

 Abrading

 Special pretreatment

# PREPARING OTHER INDUSTRIAL MATERIALS



















Most other common industrial materials likely to be bonded are covered in the table on the following page.

Engineers wishing to bond materials not covered in this manual should discuss with our technical team.

Contact

For non-metallic or non-plastic substrates, surface preparation may also be required for optimum bonding. The table hereafter provides solutions for mineral materials, rubbers, leather and wood.



| Substrate  | Preferred pretreatment (state of the art)   | Alternative solution  | Remarks  |
|--|---|---|--|
| Bricks and other fired non-glazed building materials |    | —   | Brush with a wire brush and remove dust.   |
| Carbon   |    | —   | Abrade with fine abrasive cloth or paper and remove dust.  |
| Ceramics   |    | —   | Abrade with a slurry of silicone carbide powder and water.   |
| Concrete and mortar                                  |    |    | <p>Even where concrete is sound, it should be pretreated wherever practical by one of the following methods. Method 1 is more effective than 2, and 2 is more effective than 3.</p> <ol style="list-style-type: none"> <li>1. Remove by mechanical scarification 3mm - or more - of all surfaces to be bonded, then remove dust preferably by vacuum cleaner; or</li> <li>2. Sand-blast about 1.5mm off all surfaces to be bonded, then remove dust preferably by vacuum cleaner; or</li> <li>3. SP: etching solution (annex Etchant 12).</li> </ol> |
| Earthenware  |    | —   | —  |
| Friction materials (brake pads and linings)          |    | —   | —  |
| Glass  |    |    | <p>Special pretreatment: pretreating the surface with a silane based primer will increase the bonding performance.</p> <p>Alternatively warm for 1/2 hour at 100°C and apply the adhesive before the glass cools down completely to room temperature.</p>  |
| Graphite   |  | —   | Abrade with fine abrasive paper or cloth and remove dust.  |
| Precious stones                                      |  | —   | —  |
| Leather  |  | —   | Roughen with abrasive paper & remove loose particles   |
| Paints (cataphoretic / powder coatings)              |  | —   | —  |
| Plaster  |  | —   | Allow the surfaces to dry thoroughly. Smooth with fine abrasive paper or cloth and remove dust.  |
| Rubber   |  |  | Special pretreatment: etching solution (annex Etchant 13).   |
| Stonework  |  | —   | Allow the surfaces to dry thoroughly. Brush with a wire brush and remove dust.   |
| Wood   |  | —   | Ensure the wood is dry. Plane or abrade with abrasive paper and remove dust.   |

 Degreasing

 Abrading

 Special pretreatment

# ETCHANT COMPOSITIONS

## ETCHANT 1 (ALUMINUM ETCHING)

### Composition

|   |           |
|---|-----------|
| Potassium dichromate or sodium dichromate             | 2 kg      |
| Concentrated sulfuric acid<br>(specific gravity 1.84) | 10 liters |
| Distilled/de-ionized water                            | 30 liters |

**Solution preparation:** Stir continuously whilst adding the concentrated sulfuric acid to 60% of the total water volume. Add dichromate. Stir to create a solution. Finally add the remaining water.

## ETCHANT 2 (COPPER AND COPPER ALLOY ETCHING)

### Composition

|  |           |
|--|-----------|
| Concentrated nitric acid (specific gravity 1.42) | 5 liters  |
| Distilled/de-ionized water                       | 15 liters |

**Etch for 30 seconds at room temperature in the etching solution described above. Rinse with clean, cold running water. Do not allow to dry. Immerse for 2-3 minutes at 95-100°C in a solution of:**

### Composition

|   |           |
|---|-----------|
| Sodium hydroxide  | 0.1 kg    |
| Sodium chlorite (NaCl technical)                          | 0.6 kg    |
| Trisodium phosphate ( $\text{Na}_3\text{PO}_4$ anhydrous) | 0.2 kg    |
| Distilled/de-ionized water                                | 20 liters |

**Rinse with plenty of clean cold water and dry promptly with a room temperature air stream (the use of hot air may cause staining of the surfaces).**

The two-stage chemical pretreatment above gives, in general, better bond strengths than the ammonium persulphate pretreatment below. This however offers the advantage of simplicity and the achievable bond strength may be adequate for some applications.

### **Etch in a 25% solution of ammonium persulphate:**

Immerse for 30 seconds at room temperature, wash with plenty of clean cold water and dry promptly with a room temperature air stream. (The use of hot air may cause staining of the surfaces).

**ETCHANT 3**  
**(CHROMIUM ETCHING)**

**Composition**

|   |             |
|---|-------------|
| Concentrated hydrochloric acid<br>(specific gravity 1.18) | 4.25 liters |
| Distilled/de-ionized water                                | 5 liters    |

**Immerse for 1-5 minutes at 90-95°C, rinse with clean cold running water, followed by clean hot water, and dry with hot air.**

**ETCHANT 4**  
**(LEAD ETCHING)**

**Composition**

|   |          |
|---|----------|
| Concentrated nitric acid<br>(specific gravity 1.42) | 1 liters |
| Distilled/de-ionized water                          | 9 liters |

**Immerse for 10 minutes at 45-55°C, rinse with clean running water, followed by clean hot water, and dry with hot air.**

**ETCHANT 5**  
**(MAGNESIUM AND MAGNESIUM ALLOY ETCHING)**

**Composition**

|                            |           |
|----------------------------|-----------|
| Sodium sulfate anhydrous   | 0.2 kg    |
| Calcium nitrate            | 0.2 kg    |
| Chromium trioxide          | 2.2 kg    |
| Distilled/de-ionized water | 12 liters |

**Immerse in sodium hydroxide solution (1 part to 12 parts) for 10 minutes at 70-75°C, wash thoroughly in cold tap water. Immerse in etchant 5 for 10 minutes at room temperature. Rinse thoroughly with cold tap water. Final rinse with distilled or de-ionized water. Dry in hot air and bond immediately.**

**ETCHANT 6**  
**(STEEL-MILD ETCHING)**

**Composition**

|   |           |
|---|-----------|
| Orthophosphoric acid (specific gravity 1.7) | 10 liters |
| Industrial methylated spirit                | 20 liters |

**Immerse for 10 minutes at 60°C, remove from the solution and then, under clean cold running water, brush off the black deposit with a stiff-bristle nylon brush. Absorb residual water by wiping with a clean cloth soaked with clean industrial methylated spirit or isopropanol. Heat for 1 hour at 120°C.**

# ETCHANT COMPOSITIONS

## ETCHANT 7 (STAINLESS STEEL ETCHING)

### Composition

|  |           |
|--|-----------|
| Oxalic acid (HOOC-COOH, 2H <sub>2</sub> O)             | 5 kg      |
| Concentrated sulphuric acid<br>(specific gravity 1.84) | 16 liters |
| Distilled/de-ionized water                             | 35 liters |

**Etch for 5-10 minutes at 55-65°C.**

**Prior conditioning (e.g. passivation) of the steel surface may delay the reaction between steel and etch solution. The etch treatment should be timed from the onset of the reaction. Rinse with clean cold running water, then remove the black deposit by immersing for 5-20 minutes at 60-65°C in the sulfuric acid + sodium dichromate (or chromium trioxide) etch specified for aluminum and aluminum alloys.**

\*Alternatively, remove the black deposit by brushing, under clean cold running water, with a stiff-bristle nylon brush, and dry with hot air.

Note: As wide variations in the composition of stainless steel can be encountered, prior testing should be performed to determine the optimum immersion conditions and etching solution component concentration. Etching baths used for the pretreatment of aluminum alloys must not be used concurrently for the pretreatment of steel.

## ETCHANT 8 (TITANIUM AND TITANIUM ALLOY ETCHING)

### Composition

|  |            |
|--|------------|
| Concentrated nitric acid (specific gravity 1.42) | 9.5 liters |
| Hydrofluoric acid (specific gravity 1.17)        | 0.85 liter |
| Distilled/de-ionized water                       | 40 liters  |

**Etch for 1-2 minutes at room temperature. Wash with clean cold running water, then immerse for 2-3 minutes at room temperature in a solution of:**

### Composition

|   |           |
|---|-----------|
| Trisodium phosphate (Na <sub>3</sub> PO <sub>4</sub> , 2H <sub>2</sub> O) | 1.75 kg   |
| Potassium fluoride (KF, 2H <sub>2</sub> O)                                | 0.68 kg   |
| Hydrofluoric acid (specific gravity 1.17)                                 | 1 liter   |
| Distilled/de-ionized water  | 40 liters |

**Rinse with clean cold running water, immerse in clean de-ionized water at 55-65°C for 15-20 minutes, remove, rinse with clean cold running water (brush off any remaining deposit with a clean stiff-bristle nylon brush) and dry with hot air. The temperature of the hot water and air must not be greater than 65°C.**

Frequent renewal of the de-ionized water is highly recommended. Renewing is essential if turbidity appears.

**ETCHANT 9**  
**(TUNGSTEN AND TUNGSTEN CARBIDE ETCHING)**

**Composition**

|                                 |           |
|---------------------------------|-----------|
| Caustic soda (sodium hydroxide) | 15 kg     |
| Distilled/de-ionized water      | 35 liters |

Use a stress-relieved mild-steel container: aluminum, tin and zinc-coated, galvanised or tinned ware are unsuitable for caustic soda. Mixing procedure: slowly sprinkle while stirring, flake or pearl caustic soda onto the cold water. Continue stirring until the caustic soda is dissolved. Immerse for 10 minutes at 80-90°C, rinse with clean cold running water, followed by clean hot water and dry with hot air.

**ETCHANT 10**  
**(ABS ETCHING)**

**Composition**

|  |           |
|--|-----------|
| Potassium dichromate or sodium dichromate          | 1 kg      |
| Concentrated sulfuric acid (specific gravity 1.84) | 10 liters |
| Distilled/de-ionized water                         | 30 liters |

Immerse for 15 minutes at room temperature, rinse with clean running water, followed by clean hot water, and dry with hot air.

**ETCHANT 11**  
**(THERMOPLASTIC POLYESTER ETCHING)**

**Composition**

|                            |          |
|----------------------------|----------|
| Caustic soda               | 2 kg     |
| Distilled/de-ionized water | 8 liters |

Immerse for 6 minutes at 75-85°C, wash with clean running cold water, followed by clean hot water, and dry with hot air.

**ETCHANT 12**  
**(CONCRETE / MORTAR ETCHING)**

**Composition**

|                               |           |
|-------------------------------|-----------|
| Hydrochloric or sulfamic acid | 1 liter   |
| Distilled/de-ionized water    | 10 liters |

Etch (1 liter per square meter, spread by stiff-bristle brooms) until bubbling subsides (about 15 minutes). Wash with clean water by high-pressure hose until all slush is removed and the surface is neutral to litmus. A final rinse with 1% ammonia solution followed by clean water is a good practice to ensure thorough neutralisation. Allow the surface to dry thoroughly. Remove dust preferably by vacuum cleaner.

# ETCHANT COMPOSITIONS

## ETCHANT 13 (RUBBER BLEACHING)

### Composition modified bleach solution

|   |           |
|---|-----------|
| Sodium hypochlorite<br>(standard household bleach):       | 300 ml    |
| Concentrated hydrochloric acid<br>(specific gravity 1.18) | 50 ml     |
| Distilled/de-ionized water                                | 10 liters |

**Prepare the modified bleach solution by pouring the water into a clean container made of plastic, glass or similar inert ware. While stirring the water, add the concentrated hydrochloric acid in a slow steady stream, followed by the household bleach, continuing to stir thoroughly. Never mix the household bleach and acid without adding the water first, as toxic chlorine gas will be formed. Immerse for 1-3 minutes at room temperature, wash with cold, clean water, followed by clean, hot water, and dry with hot air.**

An alternative solution is to use concentrated sulfuric acid (specific gravity 1.84). Immerse for 2-10 minutes at room temperature, rinse with clean cold running water, followed by clean hot water, and dry with hot air.





# 4.0

## APPLICATION AND BONDING METHODS

The method for applying an adhesive can range from simple hand mixing and manual application to fully automated application lines.

Selecting an appropriate application method is key to the success of adhesive bonding. The selection process includes factors such as adhesive type, part geometry, production volume, portability, quality requirements and economics.

This guide aims to provide guidance and key information for engineers to identify suitable application methods according to their specific requirements. At Huntsman Advanced Materials, our application laboratory provides support to our customers for many of the common equipment types and application methods.





#### **4.1 BASIC APPLICATION METHODS**

Selecting an appropriate application method  
Beads & dots for targeted applications  
Roller coating for large surfaces

#### **4.2 METER MIX MACHINES**

Selecting an appropriate metering pump  
Gear pumps  
Piston pumps  
Screw pumps  
Progressive cavity pumps

#### **4.3 MIXER TYPES**

Selecting an appropriate mixer type  
Static mixers for light weight and simplicity  
Dynamic mixers for hard-to-mix products

#### **4.4 CHEMICAL COMPATIBILITY**

# SELECTING AN APPROPRIATE APPLICATION METHOD

There are two main application techniques for applying reactive adhesives: bead / dot application and slot or roller coating.

The application technique is usually selected according to the size and shape of the bonded areas and the part geometry.

---

## Criteria to consider when selecting an adhesive application method include the following:

- Adhesive type
- Part size to be bonded
- Time needed to apply the adhesive
- Cycle time: number of parts to be bonded per hour / day
- Outdoor / indoor application
- Viscosity of the adhesive to be applied
- Investment level



|  | BEAD/DOT APPLICATION | SLOT/ROLLER COATING |
|--|----------------------|---------------------|
| Targeted application                         | ✓                    | ✗                   |
| Large surface application                    | ✗                    | ✓                   |
| Complex part geometry                        | ✓                    | ✗                   |
| Manual application                           | ✓                    | ✗                   |
| Robotic application                          | ✓                    | ✗                   |
| Continuous line application                  | ✓                    | ✓                   |
| Control of bond line thickness               | ✗                    | ✓                   |
| Visible bond lines / deformation             | ✗                    | ✓                   |
| Fast-cure adhesives                          | ✓                    | ✗                   |
| Use of gap-filling adhesive for uneven parts | ✓                    | ✗                   |



## 4.1 BASIC APPLICATION METHODS

# BEADS & DOTS FOR TARGETED APPLICATIONS

Beads and dots of adhesive are applied as single or multiple rows, either manually from a cartridge or from automated dispensing equipment. It is a very versatile method as it can be used for many types of adhesive from low viscosity products to highly viscous or thixotropic pastes.

This method is suitable for application of adhesives to targeted areas of parts and for three-dimensional forms. Robotic application may be combined with automated mixing / dispensing equipment to achieve consistent application even on complex forms.

For most applications, the adhesive can be dispensed directly from a disposable static mixer, meaning that there is no equipment cleaning between applications and only the disposable mixer must be changed. This application method allows fast-cure adhesives to be used.

Clamping pressure is normally applied to the bonded parts when they are brought together in order to spread the adhesive over the bonded area. However, this can lead to inhomogeneity in the bond line, or to air entrapment. If the bonded substrates are thin or flexible, this can cause an uneven surface or 'witness lines', visible on the exterior of the bonded parts.

### ADVANTAGES

- Targeted application on complex forms possible
- Very little waste
- Simple and quick cleaning of application equipment
- No need for solvent flushing
- Equipment can be very mobile
- Suited to robotic application

### DISADVANTAGES

- Precise control of adhesive thickness difficult
- Bead application pattern may be visible through thin substrates
- Relies on even pressure to spread the adhesive
- Slow application method for large, flat surfaces

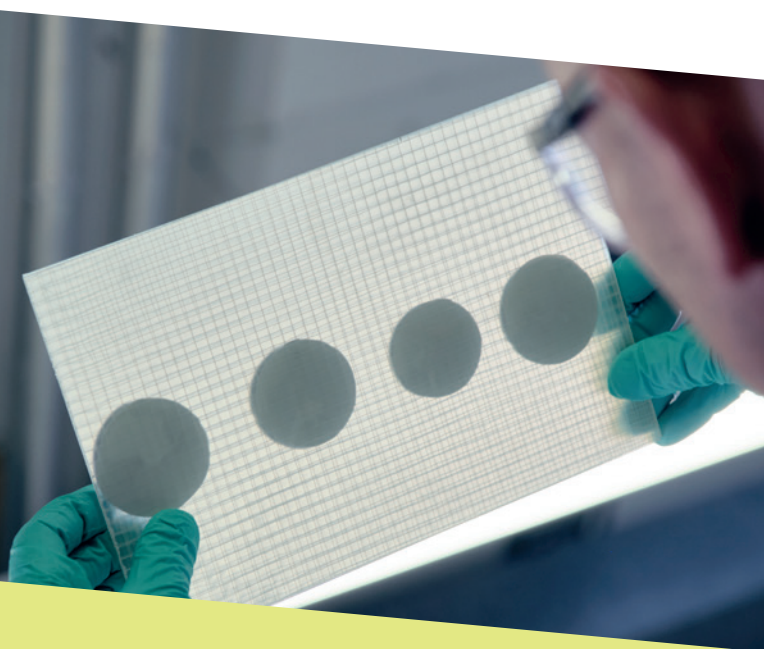

How to achieve a good beads and dots application

[▶ Watch the video](#)

## 4.1 BASIC APPLICATION METHODS

# ROLLER COATING FOR LARGE SURFACES

Usually associated with low to medium viscosity products, a film of adhesive is applied to a substrate using either a slot applicator or a roller coater. Small manual roller coaters are available, but the method often employs automated lines with an integrated coater.

This kind of applicator may also be linked to automated mixing-dispensing equipment. The installation is generally stationary (not portable) and must be flushed and cleaned regularly with solvents - e.g. at the end of a shift.

Only adhesives with relatively long working times (slow-cure) are normally suited to this kind of equipment. Very even adhesive application, with accurate control of bond line thickness can be achieved on flat substrates. This makes it especially suited for bonding large, flat panels.

### ADVANTAGES

- **Accurate control of adhesive thickness**
- **Fast application on large, flat surfaces**
- **Even bond line**

### DISADVANTAGES

- **Suitable for long open-time adhesive systems only**
- **Cleaning equipment is essential - in most cases solvent flushing / cleaning is required**
- **Equipment often not mobile**



# SELECTING AN APPROPRIATE METERING PUMP

Metering mixing equipment enables two-component adhesives to be dispensed directly from bulk packs (pails, drums or tanks).

Metering pumps have several technical characteristics which make them more or less suited to certain product types.

---

## Factors to consider when selecting metering pump type include the following:

- Output rate
- Pumping consistency / accuracy
- Flexibility to modify component mix ratios
- Adhesive viscosity / rheology
- Suitability for use with abrasive or lightweight fillers in the adhesive components
- Cost and pump maintenance



|                                     | PISTON PUMP | GEAR PUMP | SCREW PUMP | PROGRESSIVE CAVITY PUMP |
|-------------------------------------|-------------|-----------|------------|-------------------------|
| Constant output (no pulsing)        | ✗           | ✓         | ✓          | ✓                       |
| Variable component mix ratio        | ✗           | ✓         | ✓          | ✓                       |
| Low-medium viscosity fluids         | ✓           | ✓         | ✓          | ✓                       |
| High viscosity / thixotropic fluids | ✓           | ✗         | ✓          | ✓                       |
| Very high viscosity fluids          | ✗           | ✗         | ✗          | ✓                       |
| Fluids with abrasive fillers        | ✓           | ✗         | ✗          | ✓                       |
| Fluids with hollow fillers          | ✗           | ✗         | ✓          | ✓                       |
| Cost                                | ⊕ ⊕ ⊕       | ⊕ ⊕ ⊕     | ⊕ ⊕ ⊕      | ⊕ ⊕ ⊕                   |
| Variability of output rate          | ⊕ ⊕ ⊕       | ⊕ ⊕ ⊕     | ⊕ ⊕ ⊕      | ⊕ ⊕ ⊕                   |
| Pumping pressure                    | ⊕ ⊕ ⊕       | ⊕ ⊕ ⊕     | ⊕ ⊕ ⊕      | ⊕ ⊕ ⊕                   |
| Pump maintenance                    | ⊕ ⊕ ⊕       | ⊕ ⊕ ⊕     | ⊕ ⊕ ⊕      | ⊕ ⊕ ⊕                   |

The equipment has two main functions:

- Separate pumping of each adhesive component using special metered pumps. These accurately control the volume of each component to ensure the correct mixing ratio.
- Mixing of the two adhesive components as they are dispensed from the equipment.

# GEAR PUMPS

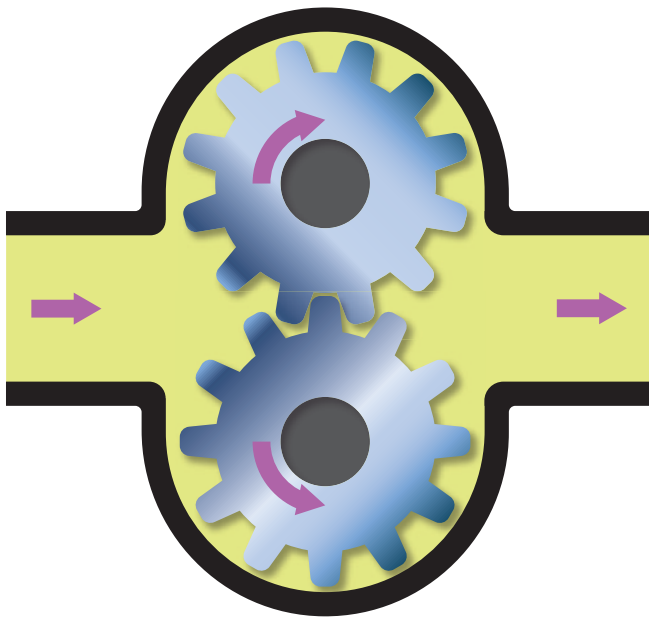

There are four main types of metering pumps used for metering-mixing of adhesives. All work on the principle of dispensing a calculated volume of material per stroke or revolution.

A gear pump operates using two driven, intermeshed gears inside a closed chamber which displace a fixed volume as they turn. Product is drawn into the revolving gears at the inlet and forced out as the gears intermesh at the outlet.

This type of pump works with low to medium viscosity materials and offers constant output, coupled with accurate volume control. The speed of each pump is variable, meaning that mix ratio can be easily adjusted. Since the pumps rely on closely intermeshing gears, they are not suited to products containing abrasive fillers, which can wear the gear parts. Gear pumps may damage lightweight fillers (hollow microspheres) causing a change in material density.

The relatively high shear rates generated by gear pumps may alter the rheological behaviour of some thixotropic adhesives (overshear) leading to sag or slumping.

## ADVANTAGES

- Constant output with no pulsing
- Extremely accurate output
- Can develop high pressure
- Simple to modify output with electric stepping motors, chain or gear drives
- Easy to change mix ratio

## DISADVANTAGES

- Cannot operate with abrasive filler systems or hollow fillers (crushing)
- Limited output for each pump size
- Due to the close tolerances of the component parts of the pump they need to be kept clean
- Can only be used on low to medium viscosity products
- Can overshear product due to pumping action



# PISTON PUMPS

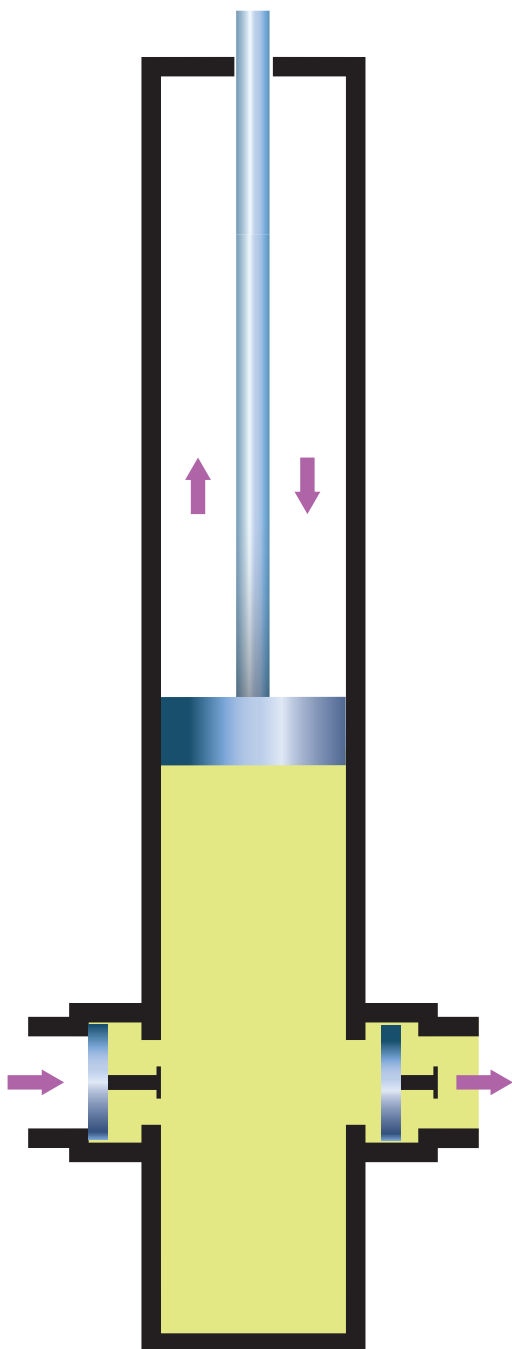

**This type of pump works on a reciprocating piston system: one stroke of a piston fills a volumetric chamber, whilst the opposite stroke discharges.**

Piston pumps generally provide accurate volume control and can be used with a wide range of material viscosities, but output is not constant due to the reciprocal nature of the pump. Some equipment uses a set of two pistons working in opposite cycles to increase consistency of the output.

Overall flow rate can be controlled, but the volume ratio of one component to another may be fixed by the piston (cylinder) bore. This means that changing adhesive mix ratio may require installation of alternative pistons/cylinders.

High pressures can be generated during the filling and discharge cycle, especially with highly viscous or thixotropic materials. This can cause breakage of hollow microspheres and lead to a gradual heating of the equipment (and adhesive) over the period of application, causing a change in reactivity. Compressible materials are particularly prone to heating with this type of pump. Piston pumps are relatively inexpensive compared to other pump types.

## ADVANTAGES

- **Very reliable**
- **Very accurate**
- **Relatively inexpensive**
- **Handles virtually all adhesive systems, low to high viscosity's as well as thixotropic materials**
- **Variable output and variable ratio**
- **Simple and well-developed technology**

## DISADVANTAGES

- **Difficult to obtain constant output**
- **Some hollow fillers like mineral spheres can be crushed, then leading to product density change**

# SCREW PUMPS

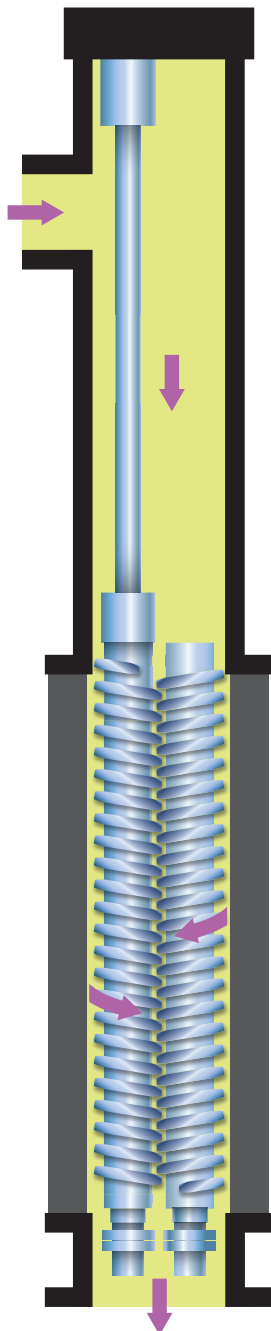

Screw pumps work using one or more rotating Archimedes' screws (spindles). Pumps for viscous materials such as adhesives typically use two or three meshing spindles, turning in opposite directions within a closed chamber. The continued rotation of the screws produces a volume displacement, transferring product from inlet to outlet.

Screw pumps have similar characteristics to gear pumps, but generate lower pressures/ less abrasion, meaning that they are more suitable for use with lightweight fillers (hollow microspheres).

Screw pumps are suitable for use with medium to high viscosity products. However, these pumps are generally more expensive than gear pumps.

## ADVANTAGES

- Constant output with no pulsing
- Extremely accurate output
- Can develop high pressures
- Simple to change output with electric stepping motors, chain or gear drives
- Easy to change the mix ratio
- Gentle on product - can operate with low pressure

## DISADVANTAGES

- Struggles to achieve high output with high viscosity products
- Cannot operate with abrasive filler systems.
- Due to the close tolerances of the component parts of the pump, they need to be kept clean
- Can overshear product due to pumping action

# PROGRESSIVE CAVITY PUMPS

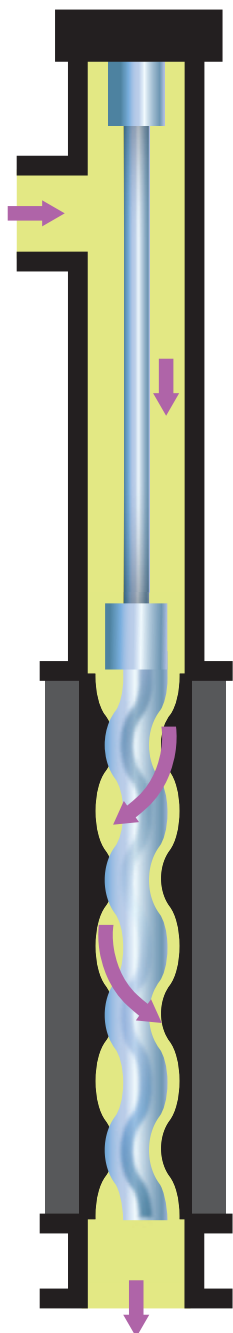

Progressive cavity pumps appear somewhat similar to screw pumps, but work by a different principle. A rigid helicoidal rotor forms cavities within a specially shaped elastomeric stator. As the rotor turns within the stator, the cavities move from the inlet to the outlet, transferring material. In this respect, the principle is similar to a peristaltic pump.

The output is constant and is modified by altering the rotor speed. Progressive cavity pumps can be used for extremely high viscosity fluids, or difficult to pump fluids, e.g. with very high filler levels.

Progressive cavity pumps apply low levels of shear to the pumped material, making them suitable for lightweight fillers (hollow microspheres). The shape of the cavities also makes them suitable for pumping fluids with large filler particles.

Some slippage can occur with cavity pumps, meaning that material passes through gaps between the rotor and stator. This worsens as parts wear and can lead to inaccurate pumping rates. The elastomeric stator therefore requires regular changing to ensure pumping accuracy.

## ADVANTAGES

- **Good for very high viscosities and other difficult media**
- **Can handle air entrained, multiple phase and abrasive fluids**
- **Precise dosing**
- **Suited to high and low viscosity applications**
- **Allows continuous, gentle and low-pulsation flow**
- **Very accurate as a metering pump**

## DISADVANTAGES

- **These pumps fail if run dry**
- **Do not produce high flow rates**
- **Volumetric efficiency affected if viscous fluid doesn't enter pumps quickly enough**
- **Can only pump a limited distance**
- **Slippage rates can be high if parts are worn**

### 4.3 MIXER TYPES

# SELECTING AN APPROPRIATE MIXER TYPE

|   | STATIC MIXER | DYNAMIC MIXER |
|---|--------------|---------------|
| Perfect mix from start of application needed            | ✗            | ✓             |
| High viscosity resin mixing with low viscosity hardener | ✗            | ✓             |
| Mixing ARALDITE® adhesive core range                    | ✓            | ✓             |
| Low investment  | ✓            | ✗             |
| Dispensing from cartridges                              | ✓            | ✗             |

## Factors to consider when selecting a mixer type include the following:

- Viscosity / rheological behavior of the adhesive
- Application type (manual cartridge or dispensing machine)
- Output rate
- Pumping pressure
- Portability
- Cleaning



#### 4.3 MIXER TYPES

# STATIC MIXERS FOR LIGHT WEIGHT AND SIMPLICITY

Two-component reactive adhesives require the components to be thoroughly mixed in order to achieve their full final properties.

Cartridges and dispensing machines are therefore usually equipped with a mixer.

**A static mixer is composed of a series of spiral or square elements aligned in a tube.**

As the two adhesive components are pumped together past each element, they are separated, creating layers. The number of layers doubles as it passes each element, meaning that 20 elements in series creates more than 1 million layers. This process effectively creates a homogenous mix of the two components.

Static mixers are generally disposable, meaning that they are lightweight, maintenance free and require no cleaning between applications. They are available in a range of sizes and can be mounted on either manual cartridges or on automated dispensing machines. Static mixers work well with low-to-medium viscosity products but may not achieve a sufficiently homogenous mix if i) the viscosity of the different adhesive components is very different, or ii) the viscosity is very high or the components are strongly thixotropic.

Static mixers tend to create a back pressure as the flow of material is constricted through them. This can lead to very high pumping pressures or low output rates, particularly if the viscosity of the adhesive is high.

#### **ADVANTAGES**

- **Suitable for cartridges and meter-mix equipment**
- **Very simple, reliable operation**
- **No cleaning required**
- **Inexpensive**

#### **DISADVANTAGES**

- **Low output with high-viscosity products**
- **Can create high back-pressure on metering pumps**
- **May not mix all product types**

# DYNAMIC MIXERS FOR HARD-TO-MIX PRODUCTS

A dynamic mixer is generally composed of a shaped (often spiral) rotor which is turned inside a tube or chamber mounted on a mixing head.

The two adhesive components are pumped through holes at the inlet and become mixed as the rotor turns. The rotor must be independently driven (e.g. electrically or pneumatically), meaning that it is not suited to manual cartridge application and that the mixing head is heavier and less portable than a static mixer.

Dynamic mixers can overcome some of the limitations of static mixers, as they will effectively mix components of very different viscosities or materials with very high viscosity.

Dynamic mixers normally require a cleaning operation between applications, such as solvent flushing or disassembly and cleaning. Dynamic mixers create low back-pressure so can be used with lower pressure pumps or to achieve high output rates.

Some automated dispensing machines use a combination of dynamic and static mixer to optimize mix quality versus the size of the mixing head.

## ADVANTAGES

- Can mix high-viscosity or highly thixotropic products
- Create low back pressure for metering machines

## DISADVANTAGES

- Only suitable for meter-mix equipment
- Increased size of mixer makes them less portable
- Cleaning / flushing necessary between applications
- Higher cost than static mixers



#### 4.4 CHEMICAL COMPATIBILITY

# CONSIDER THE CHEMICAL TYPE

| MACHINE PARTS   | EPOXY RESIN       | EPOXY HARDENER | MMA/ ACRYLATE ADHESIVES |
|---|-------------------|----------------|-------------------------|
| <b>ELASTOMERIC MACHINE SEALS (O-ring seals, seals for follower plates...)</b> |                   |                |                         |
| EPDM (ethylene propylene diene monomer rubber)                                | ✓                 | ✓              | ✓                       |
| FKM (fluorocarbon elastomer)  | O-ring seals only |                |                         |
| <b>METAL MACHINE PARTS (pipes, connectors, pumps...)</b>                      |                   |                |                         |
| Stainless steel grades AISI 304 / ISO 1.4301                                  | ✓                 | ✓              | ✓                       |
| Stainless steel grades AISI 316 / ISO 1.4401                                  | ✓                 | ✓              | ✓                       |
| Aluminium (all grades)  | ✓                 | ✗              | ✓                       |
| Steel (all grades)  | ✓                 | ✗              | ✗                       |

When choosing dispensing equipment, it is important to consider the chemical compatibility of the adhesive with the different parts of the machine.

- For manual cartridges, chemical compatibility of the adhesive components and the cartridge materials is checked by the adhesive manufacturer.
- For automated dispensing machines, it is important to consider the chemical compatibility of the adhesive with metal parts and the elastomeric machine seals. Failure to do so can result in degradation of the dispensing machine or modification of the adhesive's properties.

# 5.0

# PRECAUTIONS FOR HANDLING AND STORAGE

Huntsman ARALDITE® adhesives are generally safe to use provided that certain precautions are respected.

This guide will give an overview of the principal hazards associated with storage, handling and disposal of Huntsman's adhesives and the measures which should be taken to minimise risks during usage.

Whilst this guide offers users a general introduction to safe handling of adhesives, it is not intended to replace local workplace health & safety guidelines and regulations. In case of doubt, always seek EHS specialist advice





### **5.1 CHEMICAL TYPES OF ADHESIVES**

Acrylate / Methacrylate adhesives  
Two-component epoxy adhesives  
Two-component polyurethane adhesives

### **5.2 WORKPLACE**

Work area: separate chemical handling  
Storage: avoid product interactions  
Disposal: respect regulations  
Ventilation: reduce exposure

### **5.3 SENSITIZATION**

Respiratory sensitization from atmospheric contaminants  
Respiratory sensitization through direct skin contact

### **5.4 PERSONAL PROTECTIVE EQUIPMENT**

### **5.5 SAFETY DATA SHEET**

# CONSIDER THE DIFFERENT CHEMICAL TYPES OF ADHESIVES

HUNTSMAN adhesives are two-component products using reactive chemistry.

The ARALDITE® range comprises three principal types of adhesive, which are described below together with their associated hazards.



## PRECAUTIONS

# ACRYLATE / METHACRYLATE ADHESIVES

- 2-component acrylate and MMA adhesives generally contain acrylate and/ or methacrylate monomers as well as a cure initiator in one of the components. The initiator is normally an organic peroxide, either a liquid or a solid dispersion.
- Acrylates are irritants and known skin and respiratory sensitizers. In addition to using suitable gloves and eye protection, it is therefore recommended to ensure adequate ventilation when exposure to these products is high.
- The peroxide initiators used in this type of adhesive generally pose a low risk at the concentrations employed, and normal chemical handling precautions are sufficient (gloves and eye protection).

## PRECAUTIONS

# TWO-COMPONENT EPOXY ADHESIVES

- Epoxy adhesives generally comprise an epoxy resin component and a hardener component.
- Epoxy resins may cause mild skin and eye irritation by direct contact, but the main risk associated with epoxies is sensitization through repeated skin contact. Sensitization leads to an allergic response, normally seen as dermal eczema.
- Epoxy adhesive hardeners are generally based on amine or thiol chemistry. The principal risk associated with these materials is corrosivity, leading to strong skin irritation or even mild burns. It is therefore essential to prevent skin and eye contact using suitable eye protection and protective gloves.

## PRECAUTIONS

# TWO-COMPONENT POLYURETHANE ADHESIVES

- Polyurethane adhesives are normally composed of an isocyanate component and a polyol component.
- Isocyanates are known skin and respiratory sensitizers. In addition to suitable gloves and eye protection, adequate ventilation should be provided when working with these products. Heating of the isocyanate component or mixed adhesive (e.g. oven curing) can present a particular risk due to the increase of isocyanate vapours.
- Polyols are generally low hazard materials, but may cause skin and eye irritation, meaning that suitable protective gloves and eye protections should be used.



# MAINTAIN WORKPLACE SAFE AND TIDY

## PRECAUTIONS

### WORK AREA SEPARATE CHEMICAL HANDLING

- Avoid all storage and consumption of food or drink in the work area.
- Avoid smoking in the work area.
- Ensure that the work area is kept clean – in particular that work surfaces, floors and door/ cupboard handles are regularly cleaned to avoid chemical contamination.
- Provide adequate workplace ventilation (minimum air exchange 3-5 times per hour). Local extraction may be necessary when using respiratory sensitizers.
- Ensure that areas for hand/ face cleaning, showers and locker rooms are separated from areas where chemicals are handled.

Good industrial hygiene should always be employed when handling chemical products.

The following precautions are strongly recommended in the workplace.



## PRECAUTIONS

# STORAGE AVOID PRODUCT INTERACTIONS

- HUNTSMAN adhesives should be stored in their original, unopened containers or cartridges at the temperature indicated on the packaging (also found in section 7.2 of the SDS). Once opened, bulk containers should be re-sealed whenever possible in order to avoid i) loss of chemicals by evaporation and ii) degradation of the product from humidity / atmospheric interaction.
- Products should be protected from environmental risks such as sources of heat, strong sunlight, humidity and sources of ignition.
- Products should be separated from other chemicals, such as strong acids and bases, oxidising agents and flammable chemicals. Further information on hazardous reactions is available in section 10 of the product SDS.
- Methyl methacrylate (MMA) adhesives are highly flammable and must be stored as for flammable solvents.



## PRECAUTIONS

# DISPOSAL RESPECT REGULATIONS

- Unmixed / uncured HUNTSMAN adhesives, together with contaminated containers and packaging materials, must be disposed of as chemical waste according to local regulations.
- Cured adhesives may be disposed of as plastic waste, but care should be taken with curing of bulk material as this can generate excessive heat (exotherm), leading to smoke or even fire. Curing adhesives should be placed in metal containers away from flammable materials and sources of ignition. Sand or water may be added to containers to reduce heat in case of excessive exotherm.

## PRECAUTIONS

# VENTILATION REDUCE EXPOSURE

- Air exchange in the workplace of at least 3-5 times per hour is recommended for chemical handling.
- Localised air extraction is recommended for products presenting particular hazards, such as corrosive vapours, respiratory sensitizers or irritant dusts.
- Curing ovens can present a particular hazard, as the confined space and increased temperature can lead to high concentrations of chemical vapours. Ovens should therefore be ventilated whenever chemical products will be used in them.

## 5.3 SENSITIZATION

# PREVENT SENSITIZATION TO CHEMICALS

The main routes for sensitization are by direct skin contact to chemical products, or by inhalation of chemical vapours, dust or gases. Continued chemical exposure, causing irritation or inflammation, can lead to a person developing an allergic response, whereby even exposure to trace amounts will cause a severe reaction (e.g. eczema or industrial asthma).

Sensitization is not reversible, meaning that once a person becomes sensitized to a substance, they can no longer work with any products containing that substance. If applied consistently, good industrial hygiene can prevent sensitization in the workplace.

Sensitization occurs when repeated exposure to certain chemicals leads to an allergic reaction.



## PRECAUTIONS

# RESPIRATORY SENSITIZATION FROM ATMOSPHERIC CONTAMINANTS

Respiratory sensitization can occur when gases, vapours or dust are breathed in and enter the respiratory tract, leading to irritation, inflammation and ultimately an allergic response. Signs of respiratory sensitization are coughing or wheezing, leading to industrial asthma through repeated exposure.

- Provide suitable ventilation/ extraction to prevent exposure to chemical vapours and dusts.
- When suitable extraction cannot be assured, use suitable respirators (recommendations for respirator/ filter type can be found in section 8.2 of the product SDS).
- Take particular care when chemical products are heated, as this increases the vapour pressure leading to greater exposure.

## PRECAUTIONS

# SKIN SENSITIZATION THROUGH DIRECT SKIN CONTACT

Skin sensitization may occur in areas with repeated skin contact to chemicals. The hands and wrists are particularly at risk, but care is also needed with PPE such as glasses or masks, which are in contact with the face. Signs of skin sensitization are itching or inflammation of the exposed area leading to dermal eczema through repeated exposure.

- Use suitable chemical safety gloves and change them regularly. Ensure that they are put on and taken off correctly to avoid contamination.
- Use of additional disposable arm/ wrist protectors – e.g. when working in confined spaces or when there is a risk of splashing.
- Regular washing of the hands with soap followed by drying of hands with disposable towels (avoid the use of strong detergents or solvents for skin cleaning).
- Regular cleaning of items in direct skin contact (glasses, goggles, respirator masks, watch straps..) using a suitable detergent or isopropyl alcohol.
- Avoid chemical contamination of equipment and surfaces in the work area – e.g. door/ cupboard handles, workstation keyboards.

## 5.4 PERSONAL PROTECTIVE EQUIPMENT

# WEAR PERSONAL PROTECTIVE EQUIPMENT

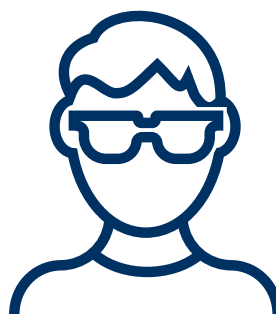

SAFETY GLASSES



RESPIRATORS



PROTECTIVE OVERALLS



PROTECTIVE GLOVES

The main goal of personal protective equipment in this context is to prevent contact of chemical products with the eyes or skin.

As a minimum, this means using suitable gloves plus eye protection (safety glasses or goggles) when handling adhesives.

Additional measures such as protective overalls and respirator masks may be required depending on the type of adhesive, volumes used, workplace ventilation and application method.

It is essential that workers are trained for correct use, cleaning and maintenance of PPE to avoid exposure.





## 5.5 SAFETY DATA SHEET

# ALWAYS REFER TO PRODUCT SAFETY DATA SHEETS

The Safety Data Sheet (SDS) is a key document to provide safety and regulatory information for use of chemical products.

Safety Data Sheets follow a standard international format comprised of 16 sections, enabling key hazard and safety data to be easily found.

### SECTION 2

#### HAZARD IDENTIFICATION

Details the main hazards and precautions associated with the product, together with the hazard pictograms which appear on the product labelling.

---

### SECTION 3

#### COMPOSITION/ CHEMICAL SUBSTANCES

A composition table lists the hazardous substances contained in the product together with their concentration ranges.

---

### SECTION 4

#### FIRST-AID MEASURES

Describes the first aid measures in case of accidental exposure to the product (e.g. by skin contact, ingestion or inhalation).

---

### SECTION 6

#### ACCIDENTAL RELEASE MEASURES

Provides recommendations on the appropriate response to spillage, leaks or environmental release.

---

### SECTION 7

#### HANDLING AND STORAGE

Details precautionary measures for handling of the product and provides advice for safe storage of the product.

---

### SECTION 8

#### EXPOSURE LIMITS/ PROTECTIVE EQUIPMENT

Details workplace exposure limits for the product (e.g. the atmospheric concentration permitted). Advises on personal protective equipment (PPE) for safe use of the product (e.g. glove and respirator filter type).

---

### SECTION 10

#### HAZARDOUS INTERACTIONS

Describes any hazardous chemical interactions which could occur to enable safe handling and storage of the product.

---

### SECTION 13

#### DISPOSAL CONSIDERATIONS

Provides recommendations for safe disposal of the product.

# MADE POSSIBLE

# HUNTSMAN

Enriching lives through innovation

## Huntsman Advanced Materials

At Huntsman Advanced Materials, we make things possible. Serving many of the world's leading businesses across virtually every industry, we enable greater innovation, performance and sustainability to address global engineering challenges and contribute towards a better quality of life.

Our capabilities in high-performance adhesives and composites, delivered by more than 1600 associates, support over 2000 global customers with innovative, tailor-made solutions and more than 1500 pioneering epoxy, acrylic, phenolic and polyurethane-based polymer products.

We operate synthesis, formulating and production facilities around the world



### For more information

[www.huntsman.com/advanced\\_materials](http://www.huntsman.com/advanced_materials)  
[advanced\\_materials@huntsman.com](mailto:advanced_materials@huntsman.com)

### Europe, Middle East & Africa

Huntsman Advanced Materials (Switzerland) GmbH  
Klybeckstrasse 200  
P.O. Box  
4002 Basel  
Switzerland  
Tel: +41 61 299 1111  
Fax: +41 61 299 1112

### Asia Pacific & India

Huntsman Advanced Materials (Guangdong) Co., Ltd.  
Shanghai Branch Office  
455 Wenjing Road, Minhang District  
Shanghai 200245, P.R. China  
Tel: +86 21 3357 6588  
Fax: +86 21 3357 6547

### Americas

Huntsman Advanced Materials Americas Inc.  
10003 Woodloch Forest Drive  
The Woodlands  
Texas 77380  
USA  
Tel: +1 888 564 9318  
Fax: +1 281 719 4047

### Legal information

All trademarks mentioned are either property of or licensed to Huntsman Corporation or an affiliate thereof in one or more, but not all, countries.

Sales of the product described herein ("Product") are subject to the general terms and conditions of sale of either Huntsman Advanced Materials LLC, or its appropriate affiliate including without limitation Huntsman Advanced Materials (Europe) BVBA, Huntsman Advanced Materials Americas Inc., or Huntsman Advanced Materials (Hong Kong) Ltd. or Huntsman Advanced Materials (Guangdong) Ltd. ("Huntsman"). The following supercedes Buyer's documents. While the information and recommendations included in this publication are, to the best of Huntsman's knowledge, accurate as of the date of publication, NOTHING CONTAINED HEREIN IS TO BE CONSTRUED AS A REPRESENTATION OR WARRANTY OF ANY KIND, EXPRESS OR IMPLIED, INCLUDING BUT NOT LIMITED TO ANY WARRANTY OF MERCHANTABILITY OR FITNESS FOR A PARTICULAR PURPOSE, NON-INFRINGEMENT OF ANY INTELLECTUAL PROPERTY RIGHTS, OR WARRANTIES AS TO QUALITY OR CORRESPONDENCE WITH PRIOR DESCRIPTION OR SAMPLE, AND THE BUYER ASSUMES ALL RISK AND LIABILITY WHATSOEVER RESULTING FROM THE USE OF SUCH PRODUCT, WHETHER USED SINGLY OR IN COMBINATION WITH OTHER SUBSTANCES. No statements or recommendations made herein are to be construed as a representation about the suitability of any Product for the particular application of Buyer or user or as an inducement to infringe any patent or other intellectual property right. Data and results are based on controlled conditions and/or lab work. Buyer is responsible to determine the applicability of such information and recommendations and the suitability of any Product for its own particular purpose, and to ensure that its intended use of the Product does not infringe any intellectual property rights.

The Product may be or become hazardous. Buyer should (i) obtain Material Safety Data Sheets and Technical Data Sheets from Huntsman containing detailed information on Product hazards and toxicity, together with proper shipping, handling and storage procedures for the Product, (ii) take all steps necessary to adequately inform, warn and familiarize its employees, agents, direct and indirect customers and contractors who may handle or be exposed to the Product of all hazards pertaining to and proper procedures for safe handling, use, storage, transportation and disposal of and exposure to the Product and (iii) comply with and ensure that its employees, agents, direct and indirect customers and contractors who may handle or be exposed to the Product comply with all safety information contained in the applicable Material Safety Data Sheets, Technical Data Sheets or other instructions provided by Huntsman and all applicable laws, regulations and standards relating to the handling, use, storage, distribution and disposal of and exposure to the Product. Please note that products may differ from country to country. If you have any queries, kindly contact your local Huntsman representative.

© 2022 Huntsman Corporation. All rights reserved.  
Ref. No. AdMat\_TechGuide\_EN\_EU\_April 2022



Registered for  
**REACH**